

monoFab
SRM-20

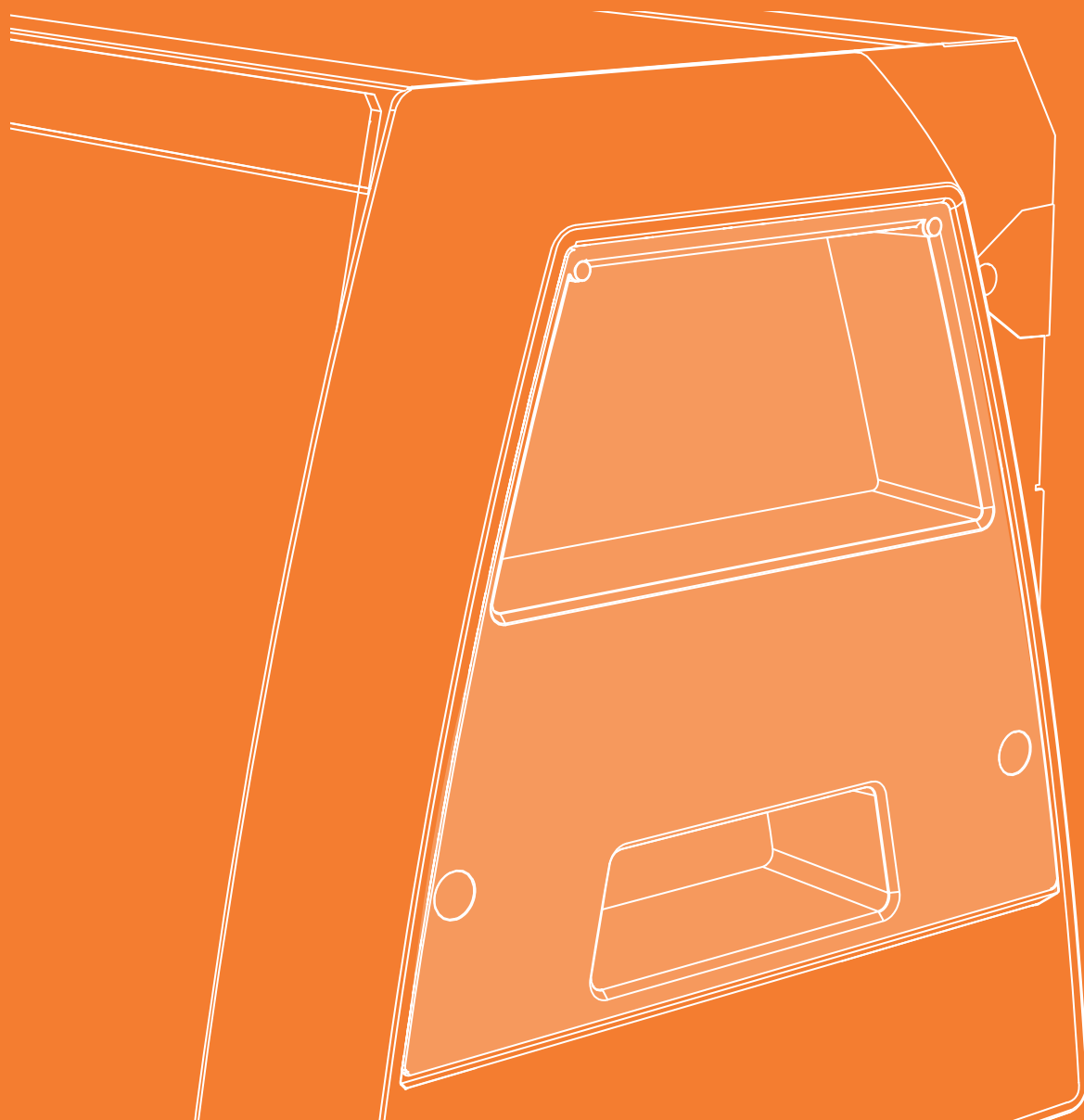

Double Sided Cutting Manual

Preparing the Machine

Guide for Cutting
with SRP Player

Guide for Cutting
with MODELA Player 4

- This manual provides basic instructions on how to perform double-sided cutting using one of the two included software programs: SRP Player and MODELA Player 4. For information on any use of SRP Player or MODELA Player 4 not covered herein, see the Help for each software program.

- ☞ User's Manual "**Display Help Dialog**"

- For information on basic operation, one-sided cutting, maintenance, and other procedures, refer to the User's Manual.

Contents

Contents	2	Creating an SRP Player File	31
Preparing the Machine	4	STEP 1 : Measure the Thickness of the Material.....	31
Preparing the Machine.....	5	STEP 2 : Determine the Size and Orientation of the Model.....	32
Flow Diagram	5	STEP 3 : Determine What to Do.....	35
STEP 1 : Turning the Power On	6	STEP 4 : Create the Cutting Data.....	37
STEP 2 : The Machine Run-in	7	STEP 5 : Preview the Result of Cutting	40
STEP 3 : Confirm the Command Set.....	9	Cutting (Double Sided).....	41
STEP 4 : Register the Cutting Tool You Want to Use (when you are using SRP Player).....	10	STEP 1 : Set the Origin Point.....	41
STEP 5 : Attach the Cutting Tool	11	STEP 2 : Perform the Roughing	42
Guide for Cutting with SRP Player.....	14	STEP 3 : Perform the Finishing.....	47
The Flow of Double-Sided Cutting	15	STEP 4 : Set the Drilling Process	52
The Flow of Double-Sided Cutting	15	STEP 5 : Drill the Scrap Board.....	56
Items Necessary for Cutting	16	STEP 6 : Reverse the Material.....	60
Items to Prepare Yourself.....	18	STEP 7 : Cut the Bottom Surface.....	62
Preparing the Material	19	STEP 8 : Remove the Cut Material.....	63
STEP 1 : Attach the Material to the Scrap Board	19	STEP 9 : Turning the Power Off	64
STEP 2 : Install the Cutting Tool.....	21	Guide for Cutting with MODELA Player 4.....	65
STEP 3 : Set the Origin Point.....	22	The Flow of Double-Sided Cutting	66
STEP 4 : Level the Scrap Board Surface.....	26	The Flow of One Side Cutting	66
STEP 5 : Perform the Surface Leveling of the Material ...	28	Items Necessary for Cutting	67
STEP 6 : Level the Bottom Surface of the Material	30	Items to Prepare Yourself.....	69



Creating a MODELA Player 4 File..... **70**
STEP 1: Load the Cutting Data..... **70**
STEP 2 : Set the Machine Selection **70**
STEP 3 : Set the Origin Point of the
Model and Orientation..... **71**
STEP 4 : Set the Material **72**
STEP 5 : Set the Number of Cutting Surfaces **72**
STEP 6 : Set the Margin..... **73**
STEP 7 : Set the Surface leveling
Process of the Scrap Board **74**
STEP 8 : Confirm the Cutting Preview **81**
STEP 9 : Set the Surface leveling
Process of the Material..... **83**
STEP 10 : Set the Roughing Process..... **88**
STEP 11 : Set the Finishing Process **93**
STEP 12 : Set the Drilling Process **97**
STEP 13 : Set the Bottom Surface Process **103**

Cutting (Double Sided)..... **105**
STEP 1 : Attach the Material to the Scrap Board **106**
STEP 2 : Set the Origin Point..... **108**
STEP 3 : Perform the Surface Leveling
of the Scrap Board **112**
STEP 4 : Perform the Surface Leveling of the Material .. **115**
STEP 5 : Perform the Roughing **116**
STEP 6 : Perform the Finishing..... **118**
STEP 7 : Perform the Drilling in the Material..... **120**
STEP 8 : Perform the Drilling in the Scrap Board..... **122**
STEP 9 : Reverse the Material..... **123**
STEP 10 : Cut the Bottom Surface..... **126**
STEP 11 : Remove the Cut Material **126**
STEP 12 : Turning the Power Off **127**

<http://www.rolanddg.com/>

Company names and product names are trademarks or registered trademarks of their respective holders.

Copyright © 2014-2015 Roland DG Corporation

Preparing the Machine

Preparing the Machine	5
Flow Diagram	5
STEP 1 : Turning the Power On.....	6
STEP 2 : The Machine Run-in	7
STEP 3 : Confirm the Command Set.....	9
STEP 4 : Register the Cutting Tool You Want to Use (when you are using SRP Player).....	10
STEP 5 : Attach the Cutting Tool	11

Preparing the Machine

Flow Diagram



*Work is unnecessary in some cases. For detail, please confirm procedure contents.

STEP 1 : Turning the Power On

Procedure

1. Close the front cover.

2. Press the  (Power) button.

The LED lamp starts flashing and it stays lit after initialization completes.

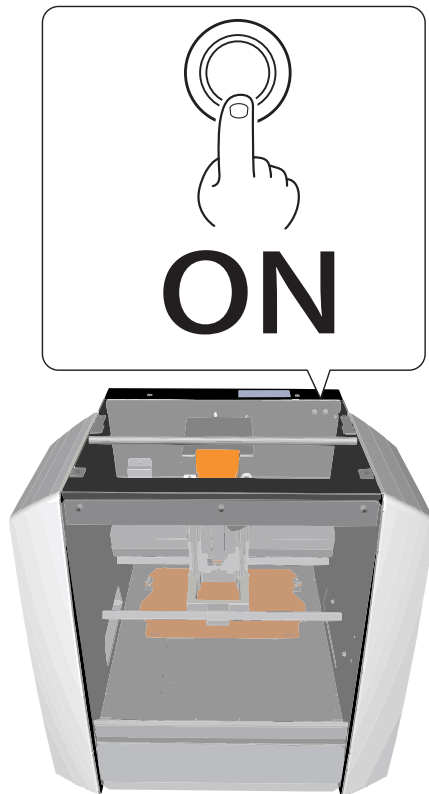

STEP 2 : The Machine Run-in

When the machine must be run-in

- When the machine is first set up
- When the consumable part is replaced
- When the machine is not used for a prolonged period

Go to the **“STEP 3 : Confirm the Command Set”** (p. 9), when the machine does not need to run-in.

Procedure

1. If a material, or cutting tool is mounted on the machine, remove it.
2. Start VPanel.
 - ☞ User's Manual **“Start VPanel”**
3. Click  at the upper left of a screen, and click **[Maintenance]**.

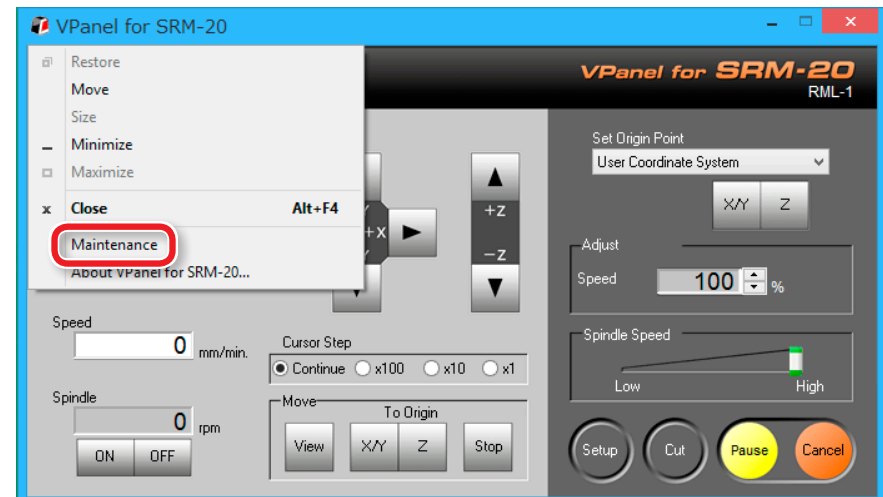



4. Click [Confirm] tab.

The screenshot shows the 'Maintenance' dialog box with the 'Spindle' tab selected. The 'Confirm' sub-tab is highlighted with a red circle. Below the sub-tab, the text 'Total Spindle Motor Rotation Time :' is followed by eight radio button options, each with a corresponding 'Hour(s)' and 'Minute(s)' input field. The options are: No.1 (selected), No.2, No.3, No.4, No.5, No.6, No.7, and No.8. A 'Reset...' button is located below the options. At the bottom of the dialog are 'OK' and 'Cancel' buttons.

5. Click [Start] of "Idling."

* Required time : Approx. 10 minutes

The screenshot shows the 'Maintenance' dialog box with the 'Spindle' tab selected and the 'Confirm' sub-tab active. The 'Idling' section is visible, featuring a 'Start' button highlighted with a red circle and a 'Stop' button. Above it, the 'Motor load' section has radio buttons for X (selected), Y, and Z, with 'Start' and 'Stop' buttons. The 'Settings' section includes 'Display' and 'Clear' buttons. At the bottom are 'OK' and 'Cancel' buttons.

When operation is completed, click [OK] and close a [Maintenance] screen.

STEP 3 : Confirm the Command Set

Select the appropriate command mode to match the software to be used.

☞ User's Manual **"Command Set"**

NC Code file outputting

☞ User's Manual **"NC Code"**

CAUTION

If a command that is sent to the machine is different from the command set selected on the VPanel, an error occurs and cutting becomes impossible.

Command Set Setting

Procedure

1. Click [Setup] on the VPanel.

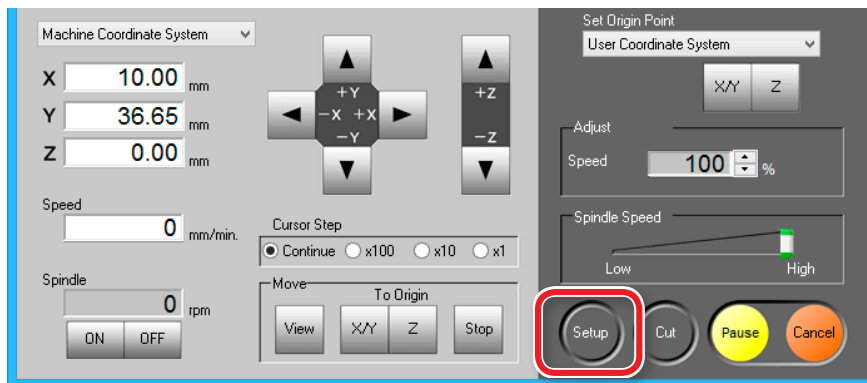

2. Select the suitable command set.

"Piano.stl" : [RML-1] → [OK]

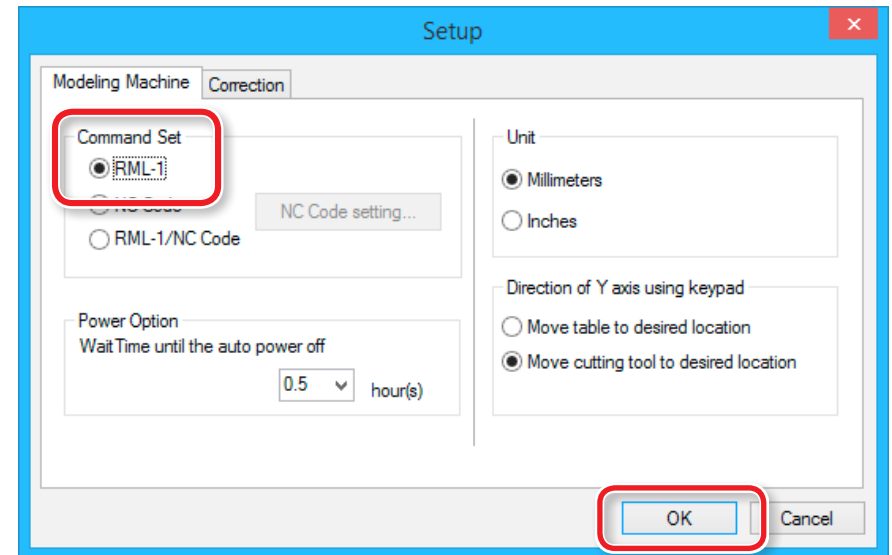

STEP 4 : Register the Cutting Tool You Want to Use (when you are using SRP Player)

Before you can use a particular cutting tool type, you need to register it with SRP Player.

You cannot use any cutting tool that has not yet been registered. Be sure to make a registration before creating an SRP Player file.

MEMO

If you are using MODELA Player 4 rather than SRP Player, proceed to **"STEP 5 : Attach the Cutting Tool"** (p. 11).

Procedure

1. On the menu bar of SRP Player, click [Options] → [My Tools...].

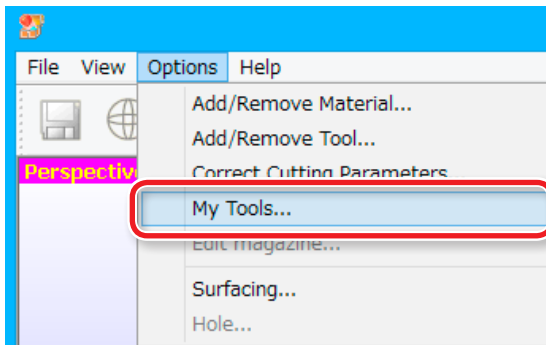

2. Register the cutting tool.

Select the check box next to the cutting tool you want to register and then click .

In the following example, **"2 mm Square"** and **"3 mm Square"** are selected.

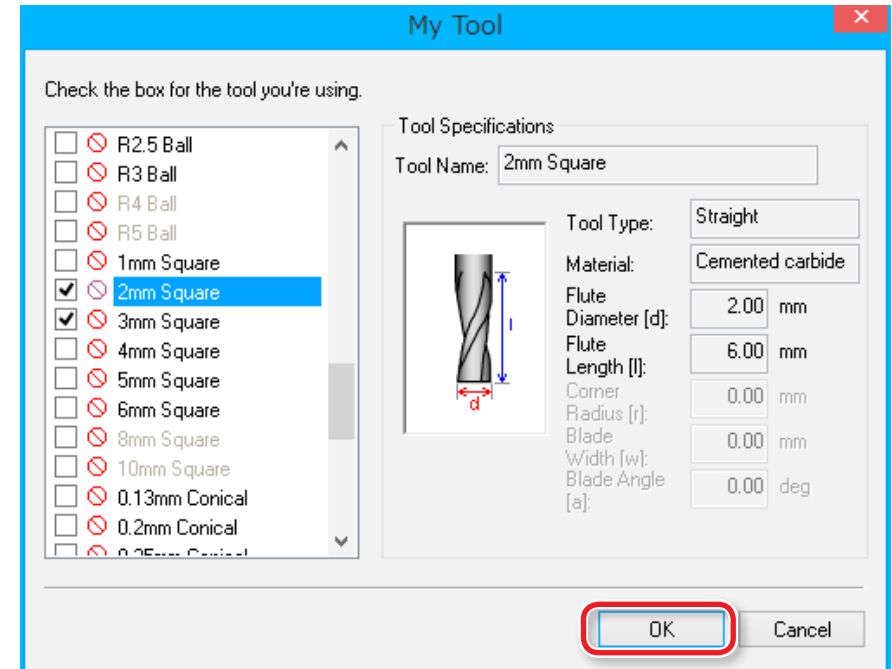



STEP 5 : Attach the Cutting Tool

Select a cutting tool matched to the purpose.

If you use the tools selectively according to the work process such as **“Roughing”** or **“Finishing”** and the design, you can obtain an even cleaner finish. Use a collet that fits the diameter of the cutting tool that will be used.

☞ User's Manual **“Cutting Tool Types”**

⚠ CAUTION

Do not touch the tip of the cutting tool with your fingers.
Doing so may result in injury.

Procedure

1. Insert a cutting tool in a collet.

Do not insert to the portion of an edge. When you use included cutting tool, refer to the following figure.

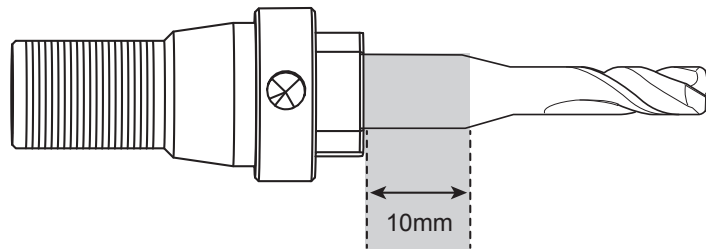

Aim of the cutting tool installation

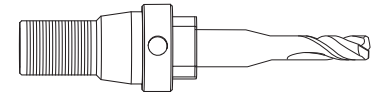

OK

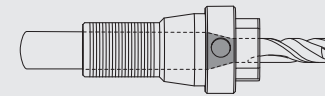

NG

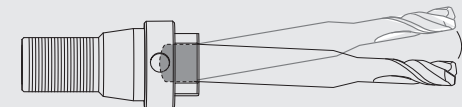

NG



2. Tighten the set screw with hexagonal wrench.

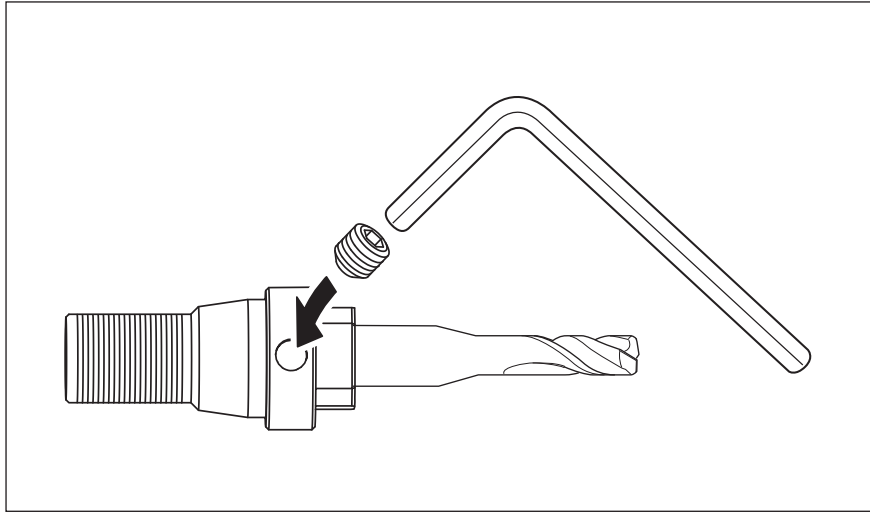

3. Click [View] of VPanel.

A spindle head moves to a center and a table moves to the front.



4. Loosely tighten the collet with cutting tool.

Insert the collet, and then loosely tighten.

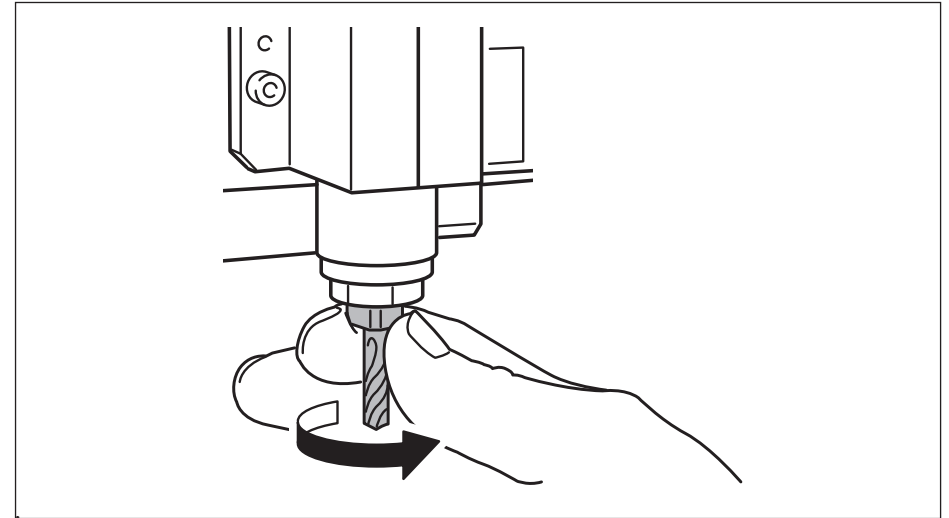

5. Fully tighten the collet.

Tightly secure the collet by using two spanners.

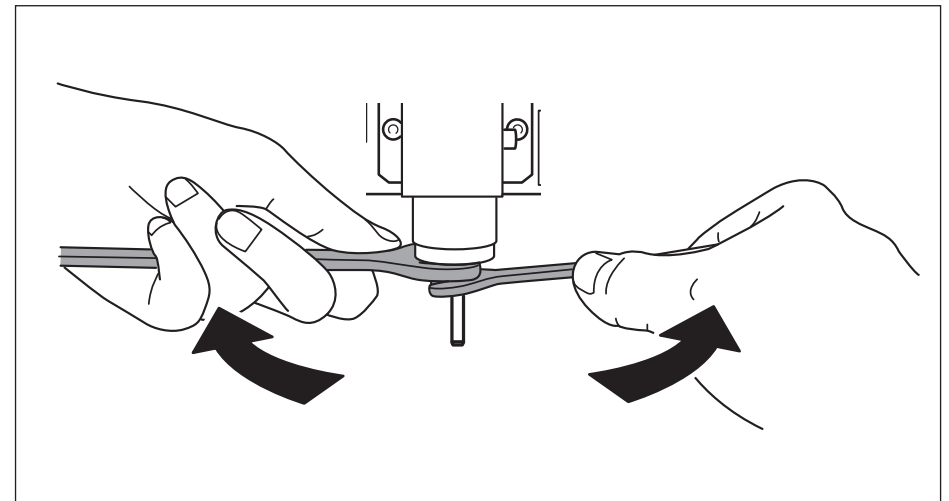



When changing to a cutting tool with the same shank diameter

⚠ CAUTION Do not touch the tip of the cutting tool with your fingers. Doing so may result in injury.

Procedure

- 1. Loosen the set screw with hexagonal wrench.**
Support lightly by hand not to drop a cutting tool.

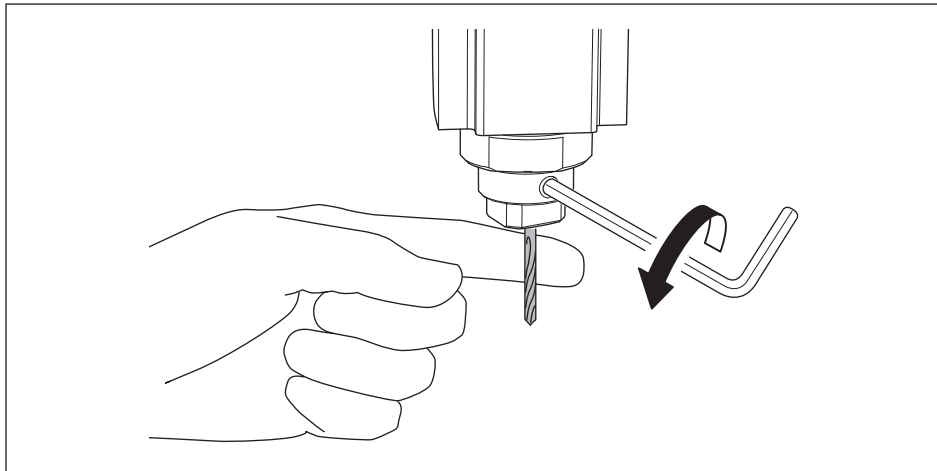

- 2. Remove the cutting tool.**
- 3. Attach the cutting tool which you want to use ,and tighten the set screw.**

When changing to a cutting tool with a different shank diameter

Procedure

- 1. Remove the collet from machine.**
Refer to the procedure 4 to 5 of **“STEP 5 : Attach the Cutting Tool”** (p. 11) in revers order, remove the collet.
- 2. Attach the cutting tool.**
Refer to the procedure of **“STEP 5 : Attach the Cutting Tool”** (p. 11), attach the cutting tool.

Guide for Cutting with SRP Player

The Flow of Double-Sided Cutting 15

The Flow of Double-Sided Cutting..... 15

Items Necessary for Cutting 16

Items to Prepare Yourself..... 18

Preparing the Material..... 19

STEP 1 : Attach the Material to the Scrap Board 19

STEP 2 : Install the Cutting Tool..... 21

STEP 3 : Set the Origin Point..... 22

STEP 4 : Level the Scrap Board Surface..... 26

STEP 5 : Perform the Surface Leveling of the Material..... 28

STEP 6 : Level the Bottom Surface of the Material 30

Creating an SRP Player File 31

STEP 1 : Measure the Thickness of the Material..... 31

STEP 2 : Determine the Size and Orientation of the Model... 32

STEP 3 : Determine What to Do..... 35

STEP 4 : Create the Cutting Data..... 37

STEP 5 : Preview the Result of Cutting 40

Cutting (Double Sided) 41

STEP 1 : Set the Origin Point..... 41

STEP 2 : Perform the Roughing 42

STEP 3 : Perform the Finishing..... 47

STEP 4 : Set the Drilling Process 52

STEP 5 : Drill the Scrap Board..... 56

STEP 6 : Reverse the Material..... 60

STEP 7 : Cut the Bottom Surface..... 62

STEP 8 : Remove the Cut Material..... 63

STEP 9 : Turning the Power Off 64

The Flow of Double-Sided Cutting

The Flow of Double-Sided Cutting

In this manual, a procedure is explained by the method using "Perfume.stl." If it does as a procedure, it can cut, as shown in the following figure.

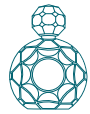

"Items Necessary for Cutting" (p. 16)



"Preparing the Machine" (p. 5)



"Preparing the Material" (p. 19)



"Creating an SRP Player File" (p. 31)



"Cutting (Double Sided)" (p. 41)



Items Necessary for Cutting

Software Applications Necessary for Sample Cutting

☞ Download "<http://startup.rolanddg.com>"





SRP Player

☞ User's Manual "**About SRP Player**"

☞ "**Cutting (Double Sided)**" (p. 41)

Machine Accessories Necessary for Sample Cutting

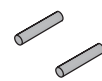
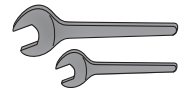
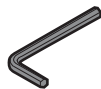
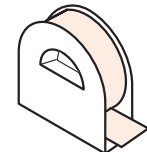
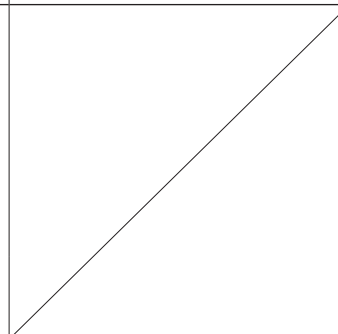
 <p>Collet (1)</p>	 <p>Cutting tool (1)</p>	 <p>Set screw (1)</p>	 <p>Positioning pin (2)</p>
 <p>Spanner L / S (one for each)</p>	 <p>Hexagonal wrench, small (1)</p>	 <p>Double-stick tape (1)</p>	



Sample Cutting Data

Installing SRP Player installs sample data as well.
(When the SRP Player is installed on drive C)

C:\ProgramData\Roland DG Corporation\SRPPlayer\Sample

“Perfume.stl” Data Size

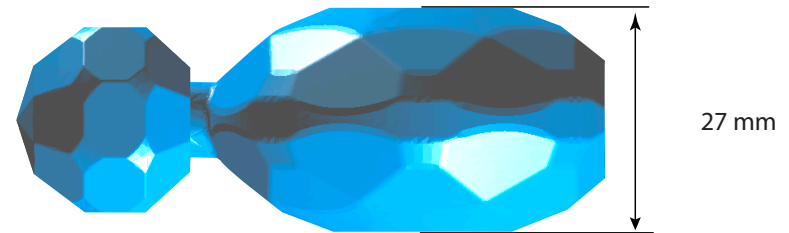
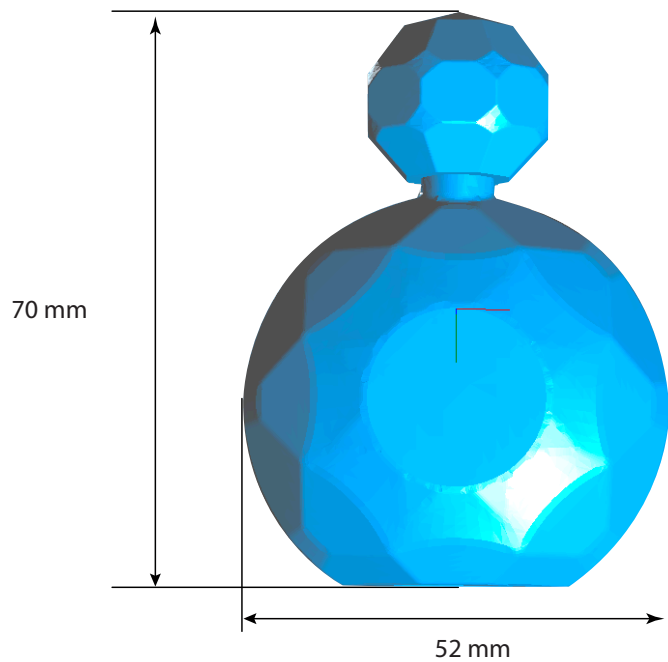



Items to Prepare Yourself

* The dimensions below are a reference size for the sample. This manual lists the values when a material and a scrap board with the following dimensions have been prepared.

Material

Make sure that the material is larger than the size specified in the data. At the same time, taking into account the size of the scrap board that will be used, make sure that the material is small enough to fall within the cutting range of this machine. Too large a size could result in collision with moving parts, possibly leading to the breakage of the material or jig or other failure.

☞ User's Manual **"Cutting Area"**

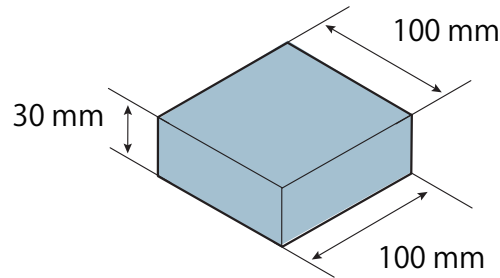

 The data size can be set for the size of the material.
☞ **"Set the Size of Cutting Data"** (p. 71)

Scrap Board



A scrap board is a board that is placed under the material when cutting it so that the table is not cut.

Ensure that the scrap board is larger than the material and is of a size that can be affixed to the table (150 x 200 mm). When performing double-sided cutting using the positioning pins, the thickness of the scrap board must be at least 6 mm.

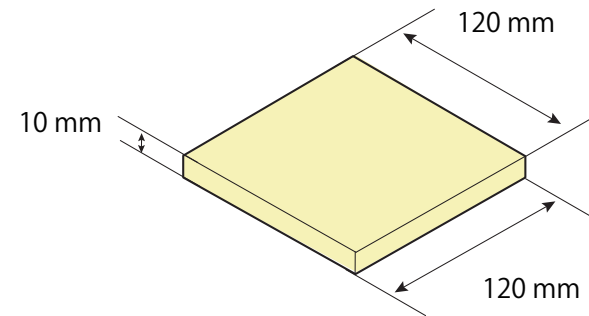
☞ **"Reversal process using positioning pins"** (p. 52)

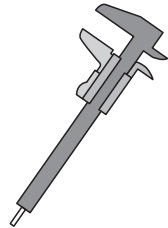

Others

 <p>Slide calipers</p>	 <p>Cutting tool with a shank diameter of 6 mm and with a tip diameter of 2 mm</p>
---	---

STEP 1 : Attach the Material to the Scrap Board

Scrap Board

A scrap board is a board that is placed under the material when cutting it so that the table is not cut.

It is used as a temporary, subsidiary material when cutting out the material or when drilling holes for positioning when cutting.

☞ User's Manual "**Cutting Material / Scrap Boards**"

Procedure

1. Mark the location that will be the origin point of the scrap board.

Draw the diagonal line and mark the center point of the scrap board.

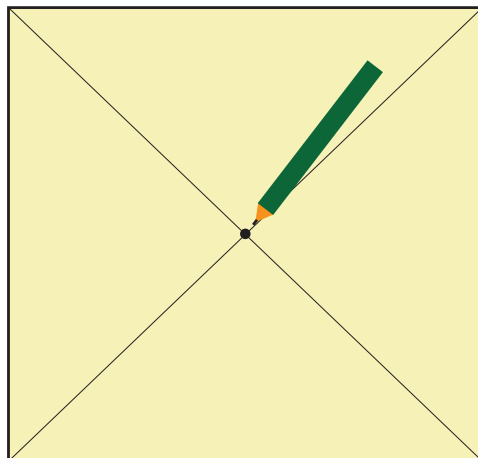

2. Stick double-stick tape on the scrap board.

An adhesion side is made large so that the scrap board may not separate during cutting.

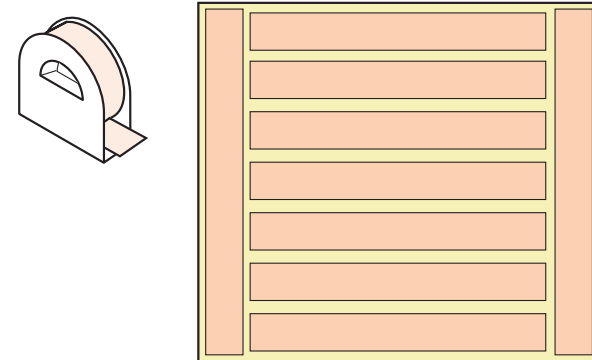



3. Click [View] of VPanel.



4. Pull down the front guard and loosen the screws at the positions shown in the figure.

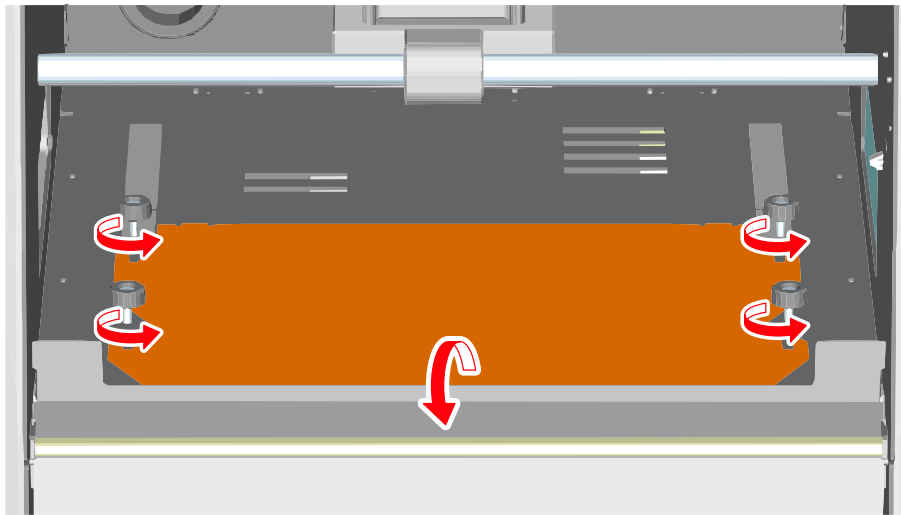

5. Affix the scrap board to the removed table, and slot the table under the screws.

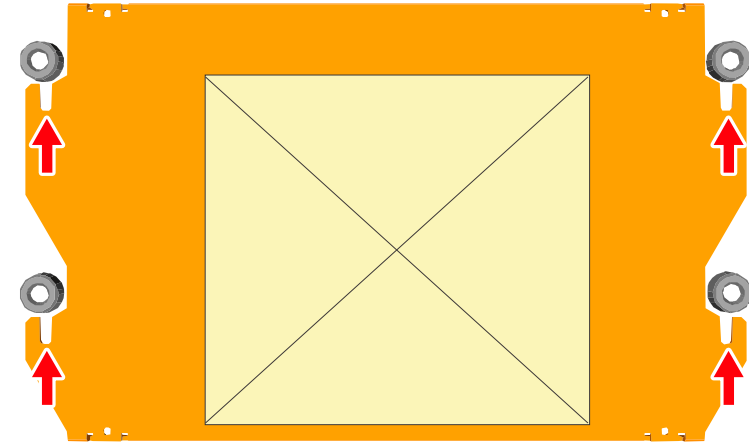

Front

6. Tighten the screws firmly and return the front guard to the original position.

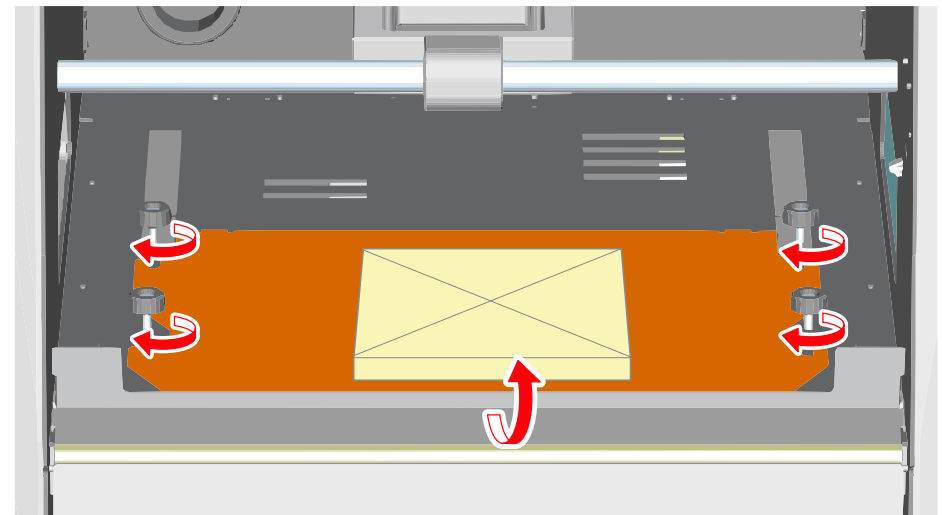



STEP 2 : Install the Cutting Tool

Select a cutting tool matched to the purpose.

If you use the tools selectively according to the work process such as **[Roughing]** or **[Finishing]** and the design, you can obtain an even cleaner finish. Use a collet that fits the diameter of the cutting tool that will be used.

☞ **“STEP 5 : Attach the Cutting Tool”** (p. 11)

CAUTION

Do not touch the tip of the cutting tool with your fingers.
Doing so may result in injury.

STEP 3 : Set the Origin Point

About Origin Point

Before you start cutting, you must set the origin point. When you cut with this machine, you need to set the X, Y, and Z origins.

The X and Y origins are determined by the cutting data and the location of the material. (“X” and “Y” cannot be set individually.) You normally align the Z origin with the surface of the material. Take the size of the material and the length of the cutting tool into consideration when you set the origins.

In addition, the locations that you should specify for the origins vary depending on the application software that you are using. Set up depending on the specification of the application software that you are using.

☞ User’s Manual “Origin point of the Model / Origin point”

1. Prepare to set the origin point

1. Select [Machine Coordinate System] on the VPanel.



2. Click [X/Y][Z] of [Origin] in [Move].

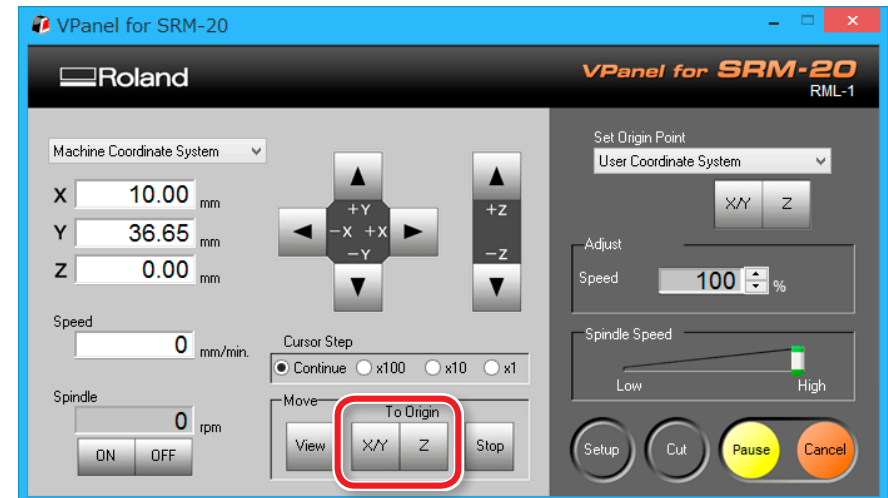



3. Check that XYZ is "0.00 mm."

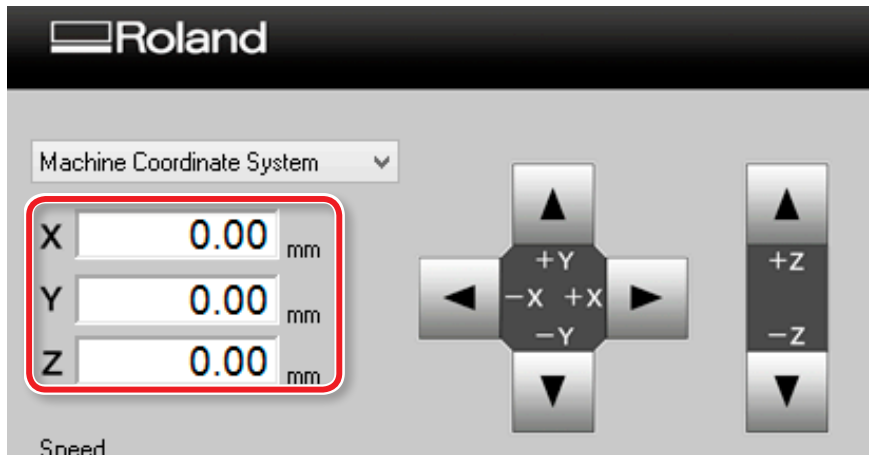

4. Select [User Coordinate System], check that XYZ is "0.00 mm."

If "0.00 mm" does not appear for X, Y and Z, click [X/Y], then [Z] under set origin point.



2. Set the origin point

1. Click [X][Y] feed button, move right above the origin point which put the mark by STEP1.

☞ User's Manual "Direction of Y axis using keypad"

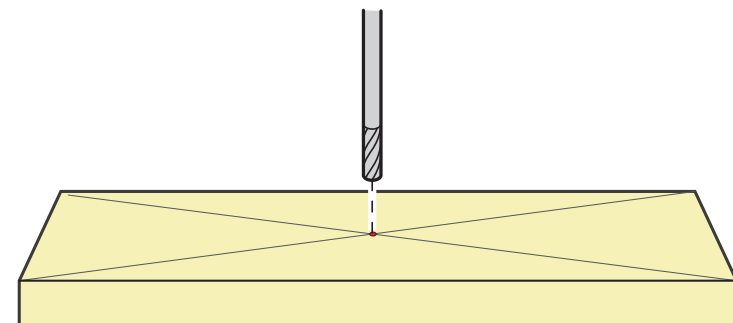
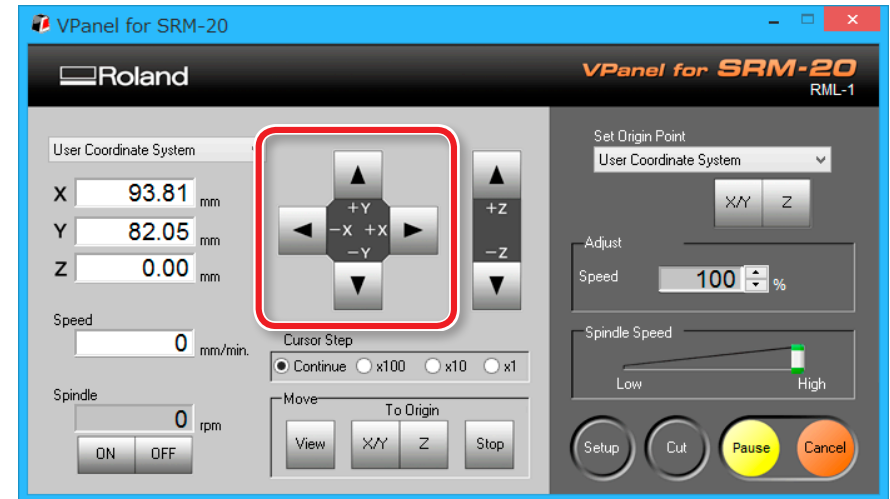



2. Click the [- Z] feed button, to approximate the tip of the cutting tool to the surface of the material as much as possible.

For loosening the set screw with the next procedure, move to the position that can see the hole of the set screw (to loosen the set screw with the hexagonal wrench).

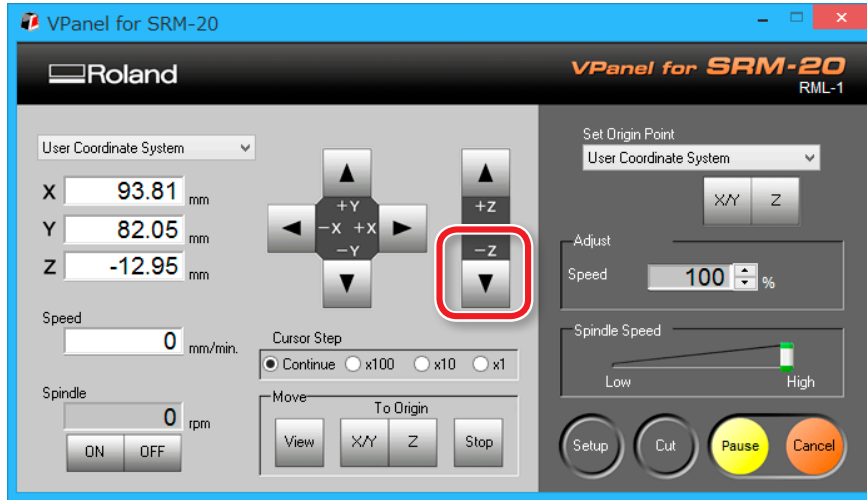

3. Loosen the set screw, and then adjust the cutting tool so that its tip contacts the surface of the material.

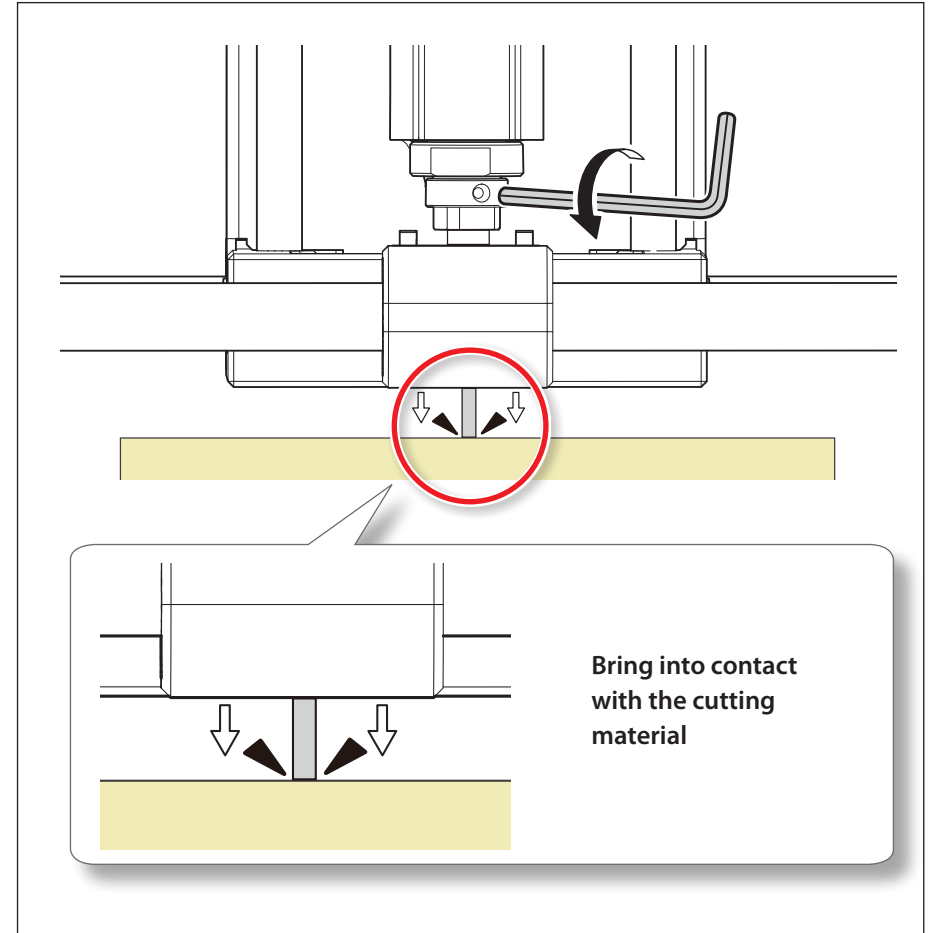



4. Tighten the cutting tool in place again with the set screw.

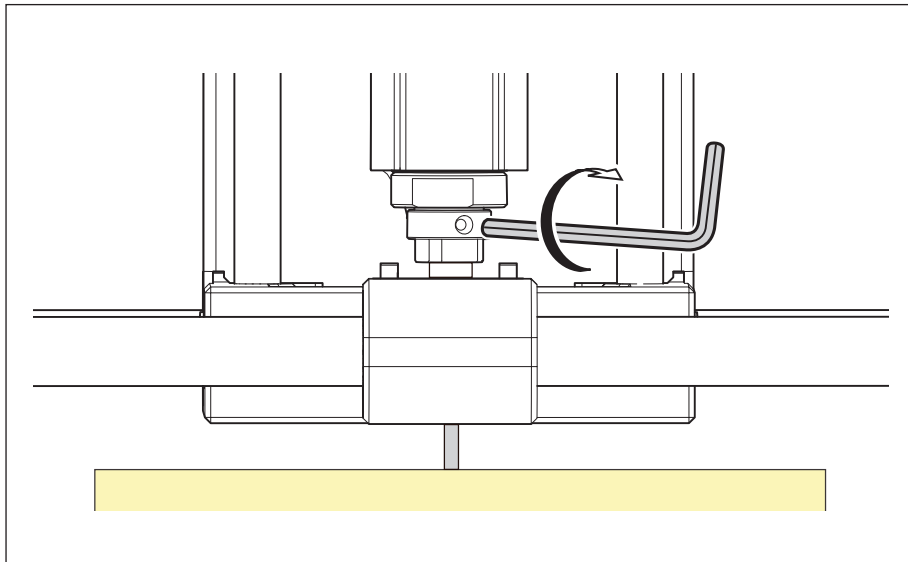

5. Click [X/Y][Z] of set origin point.



6. Click [YES].

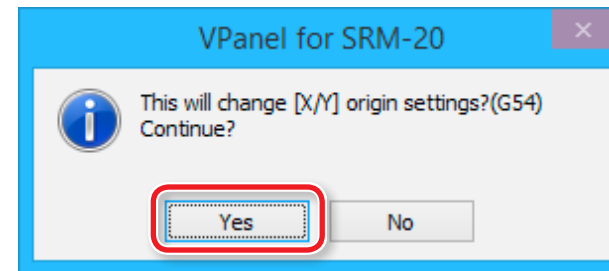

7. Confirm that the coordinates have all become "0."

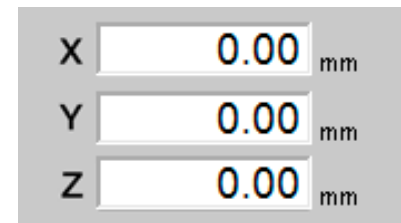

STEP 4 : Level the Scrap Board Surface

The points to be checked before cutting

Check the following thing before starting cutting. If there are problems with any of these, the cutting material may be wasted or the machine may be damaged.

- Is an output file right?
- Have you made a mistake with the origin point position?
- Do the cutting conditions match the type of cutting material?

Procedure

1. On the menu bar of SRP Player, click [Options] → [Surfacing...].

2. On the dialog that appears, configure leveling cutting range, depth, and other settings.

This example assumes that the following options are configured:

- Material : Chemical Wood (Soft)
- Tool : 3 mm Square
- Orbit Direction : Up Cut
- Depth : 1.00 mm
- X : 100.00 mm
- Y : 100.00 mm

When you are done, click .

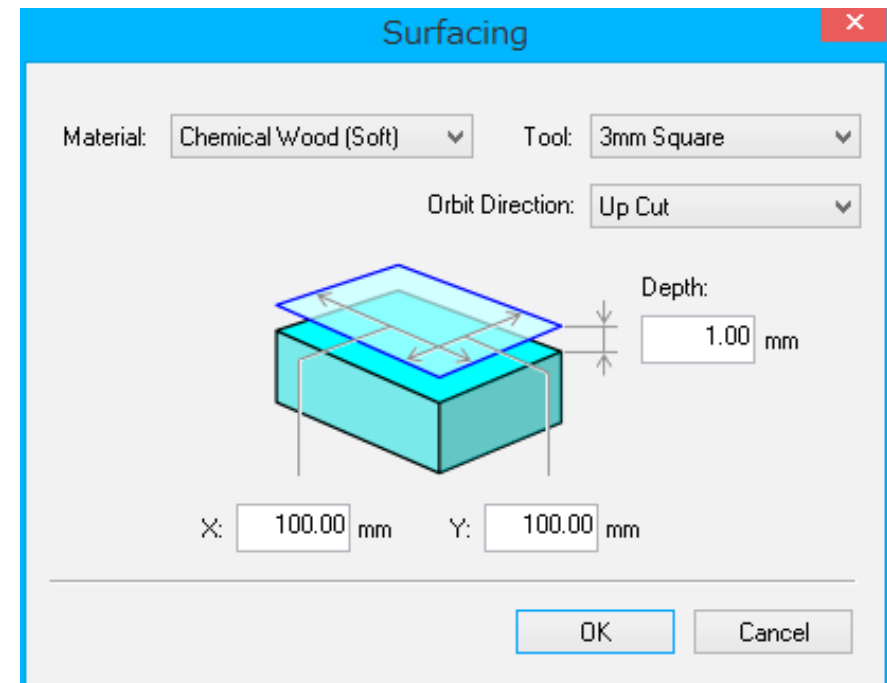

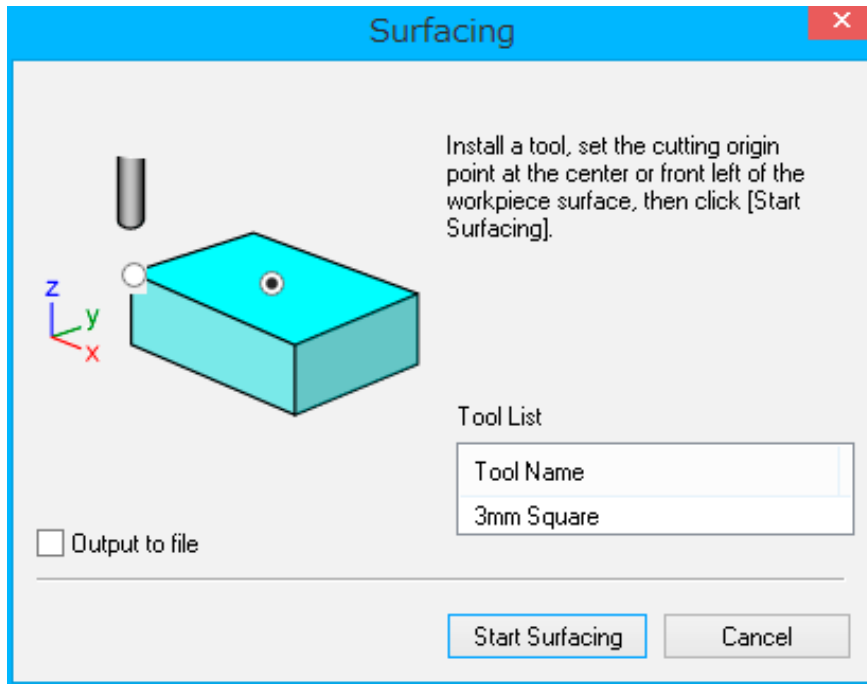

3. Make sure that the desired tool and origin position are correctly set up and then click **Start Surfacing**.

**MEMO**

VPanel allows you to pause or cancel the cutting.

- ☞ **“Pausing / Resuming”** (p. 113)
- ☞ **“Cancel the Cutting”** (p. 114)
- ☞ **“Caution of Cutting After an Emergency Stop and a Shutdown”** (p. 114)

STEP 5 : Perform the Surface Leveling of the Material

Attach the material using the same procedure as the scrap board, and perform surface leveling.

Procedure

1. Attach the material to the scrap board.

* Mark the location that will be the origin point of the material.

MEMO

If you mount it in a position in the front, the work will be easier.

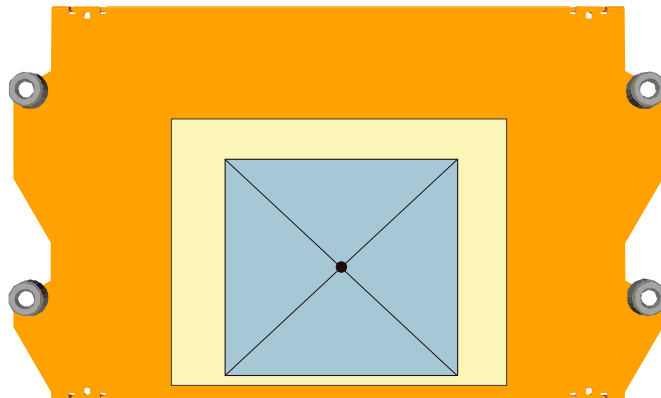

Front

2. Set the origin point to suit the material.

☞ "STEP 3 : Set the Origin Point" (p. 22)

3. Level the material surface.

Level the material surface using the same procedure as when leveling the scrap board surface.

☞ "STEP 4 : Level the Scrap Board Surface" (p. 26)

Precautions to Take When Leveling the Material Surface

* Make sure to reset the Z origin point to suit the material.

Failure to perform this operation may result in the cutting tool hitting the material, which may cause the material to come loose and damage the cutting tool.

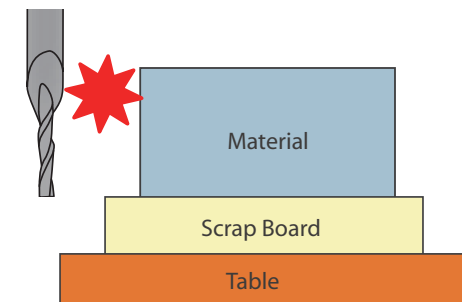
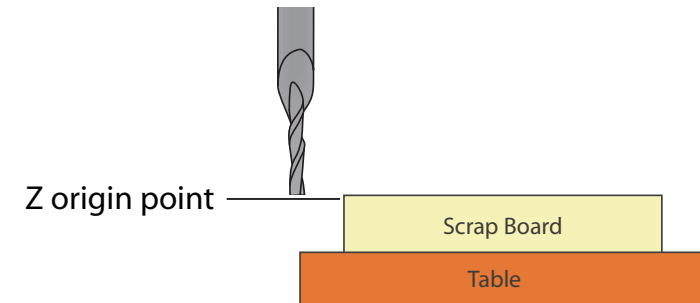



4. Click the [View] button on the VPanel.

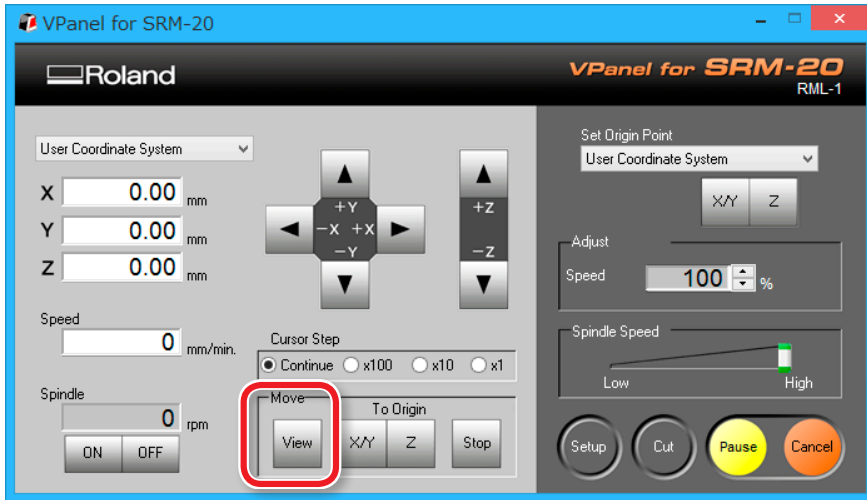

5. Remove the cutting waste and remove the material.

Remove the double-stick tape on the back of the material.



When material cannot remove finely, it removes using wooden spatulas etc.



STEP 6 : Level the Bottom Surface of the Material

Level the bottom surface of the material using the same procedure as when leveling the top surface.

☞ **“STEP 5 : Perform the Surface Leveling of the Material”** (p. 28)

STEP 1 : Measure the Thickness of the Material

As part of creating an SRP Player file, you will have to set the material size. So, determine in advance how thick the material should be after surface leveling.

☞ **"3. Set the material size."** (p. 38)

Measure the thickness of the material.

Make an accurate measurement using slide calipers.

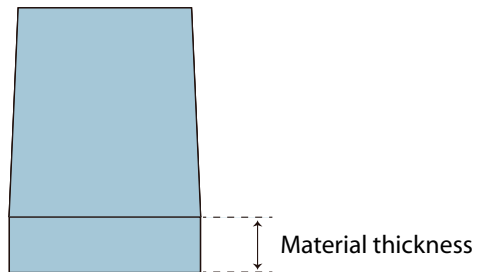

STEP 2 : Determine the Size and Orientation of the Model

Load an IGES, DXF (3D), or STL format file to set the size and orientation.

☞ **“Sample Cutting Data”** (p. 17)

MEMO

For details on how to change the settings, see the [\[Help\]](#).

☞ User’s Manual **“Display Help Dialog”**

Procedure

1. Start SRP Player.

☞ User’s Manual **“Starting SRP Player”**

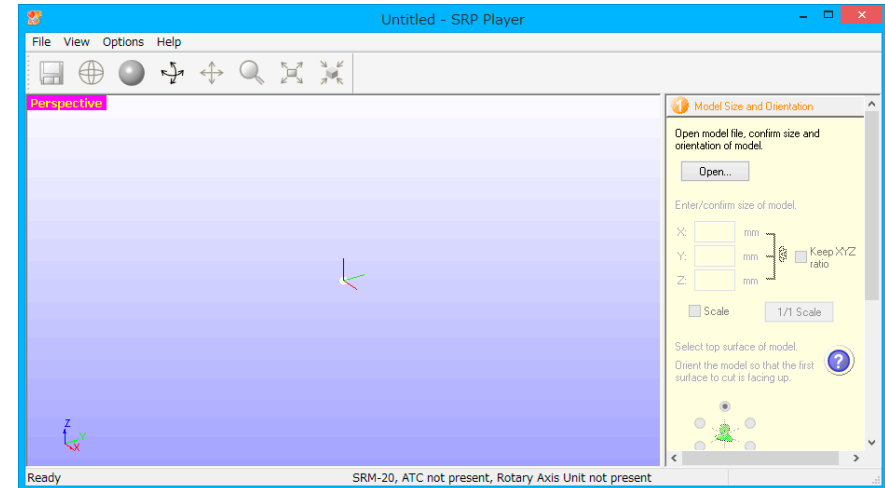



2. Open the cutting data model.

2-1. Click **[Open]**.

2-2. Select the cutting data model ("**Perfume.stl**"), and click **[Open (O)]**.

Storage location of sample cutting data model

C:\ProgramData\Roland DG Corporation\SRP Player\Sample

(When the SRP Player is installed on drive C)

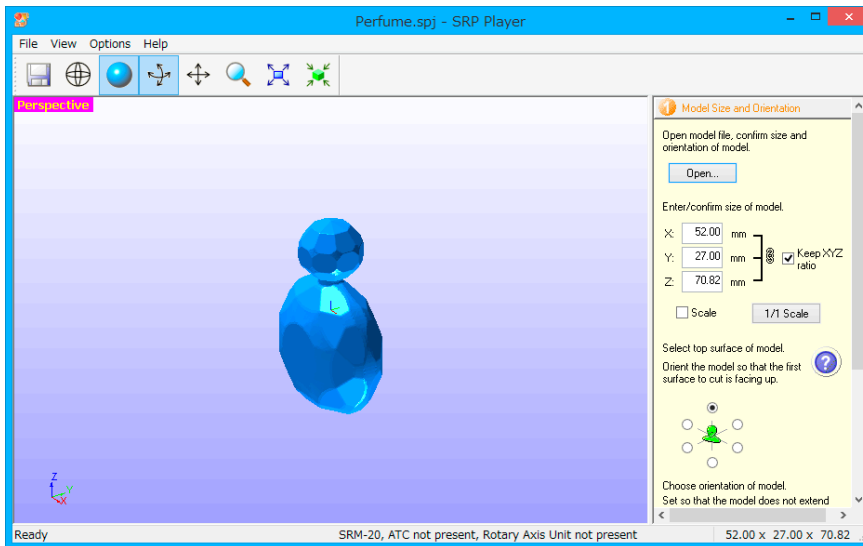

3. Configure the size settings in the cutting data.

The dialog displays the X, Y, and Z size settings for the currently open model. You can change the size settings by entering new values into the X, Y, and Z boxes.

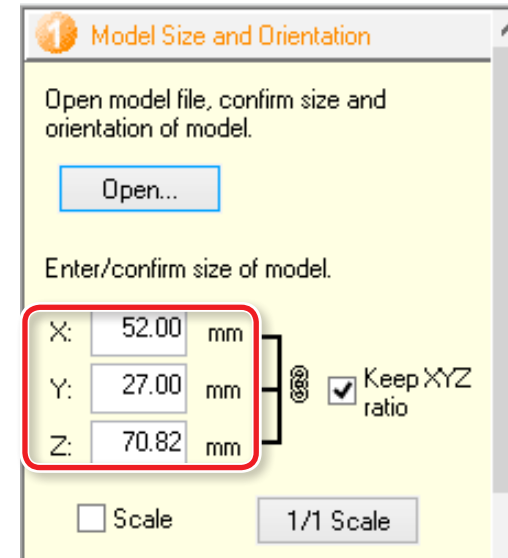

MEMO

Clicking **[1/1 Scale]** restores the original size.

MEMO

When the **[Scale]** check box is selected, you can enter the model size settings as a percentage.



4. Select the top surface of the cutting data model.

Turn up the face that will be ground first.

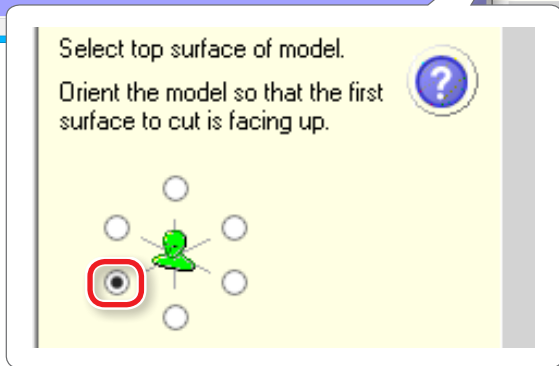
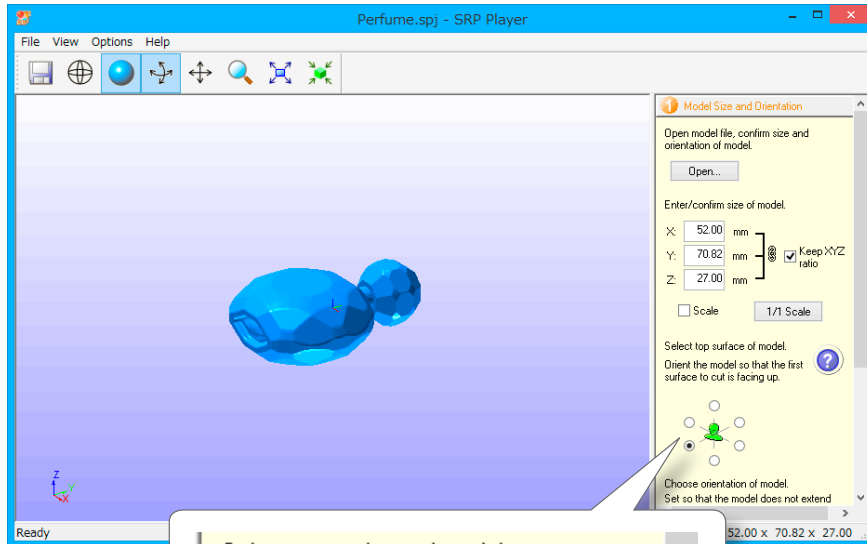

Changing the top surface changes the X, Y, and Z dimension values as well.

A message appears if the size exceeds the movable range of the machine.

Change the size of the model according to a message.

STEP 3 : Determine What to Do

Procedure

1. Click  .

2. Select any options that suit your needs.

This example assumes that the following options are configured:

- [Better surface finish]
- [Model with many curved surfaces]
- [Block workpiece]
[Cut top and bottom]

MEMO

For details on selection criteria, see the [Help].

☞ User's Manual "Display Help Dialog"

IMPORTANT

You have to configure all the settings before you can proceed to STEP 3.

2 Type of Milling

Select the type of milling.

Better surface finish
 Faster cutting time

?

Model with many flat planes
 Model with many curved surfaces

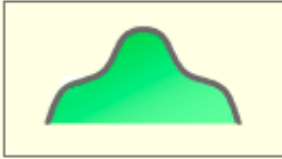
?

Cylindrical workpiece
 Block workpiece

Eccen- tricity...

Cut top only
 Cut top and bottom

Add support to model

Edit...

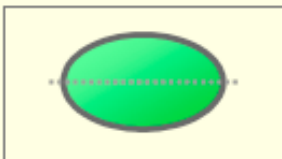
?



3. Add supports to the model.

Select the **[Add support to model]** check box and click **Edit...**

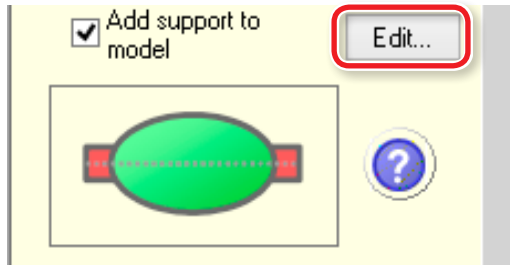

4. Position and size the support.

4-1. Set the position and length of the support by dragging it on screen.

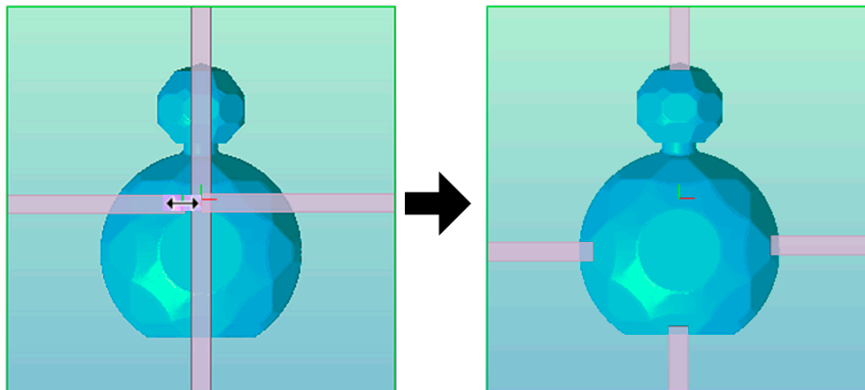

4-2. Enter the Support Width and the Support Height.

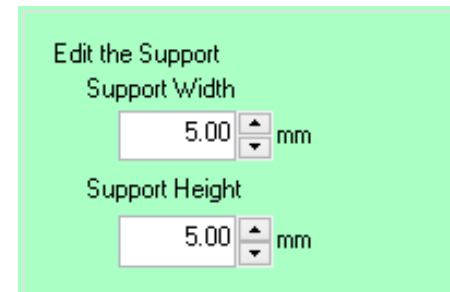

4-3. Change the perspective and preview the result.

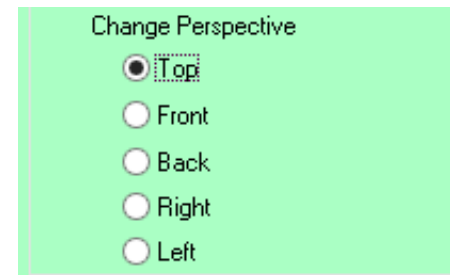

CAUTION

The machine will not cut any portions where the support is visible. Therefore, arrange the support so that it will not hinder the creation of the model geometry.

4-4. Click **Apply** to save the changes and then click **Close** to return to the previous screen.

STEP 4 : Create the Cutting Data

Procedure

1. Click  .

2. Select the material.

Choose a workpiece material from the pull-down list.

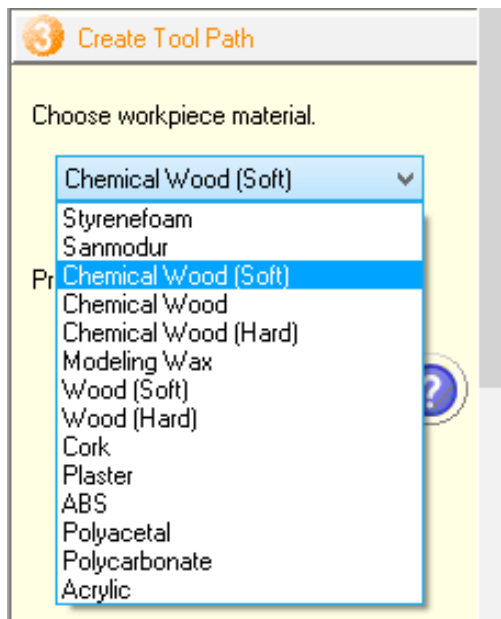

IMPORTANT

Be sure to select a correct material. Selecting a wrong material would result in failure to correctly configure the cutting conditions.



3. Set the material size.

Set the material size so that it fits the cutting data model size and the size of the part you want to create.

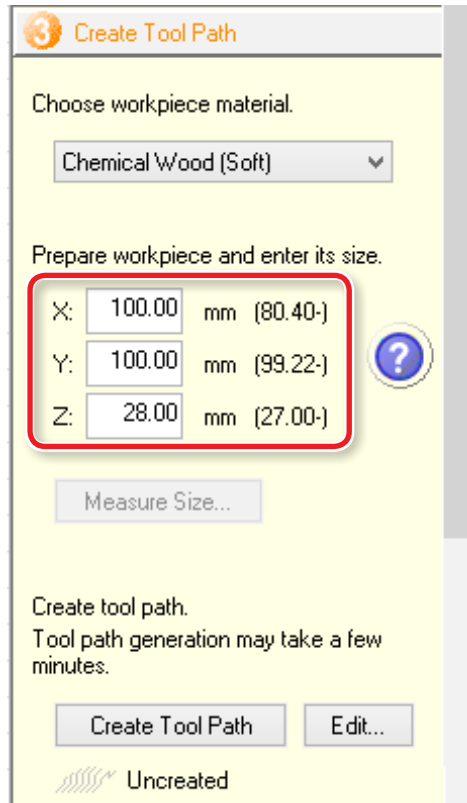

MEMO

For details on how to change the settings, see the [\[Help\]](#).

☞ User's Manual **"Display Help Dialog"**

MEMO

Minimum material dimension values appear in parentheses.
You cannot enter a dimension smaller than the minimum.

This example assumes that the following options are configured:

X : 100 mm

Y : 100 mm

Z : 28 mm

☞ **"Items to Prepare Yourself"** (p. 18)



Populate the **[Z]** field with the material thickness you measured using calipers in STEP 1.

☞ **"STEP 1 : Measure the Thickness of the Material"** (p. 31)

MEMO

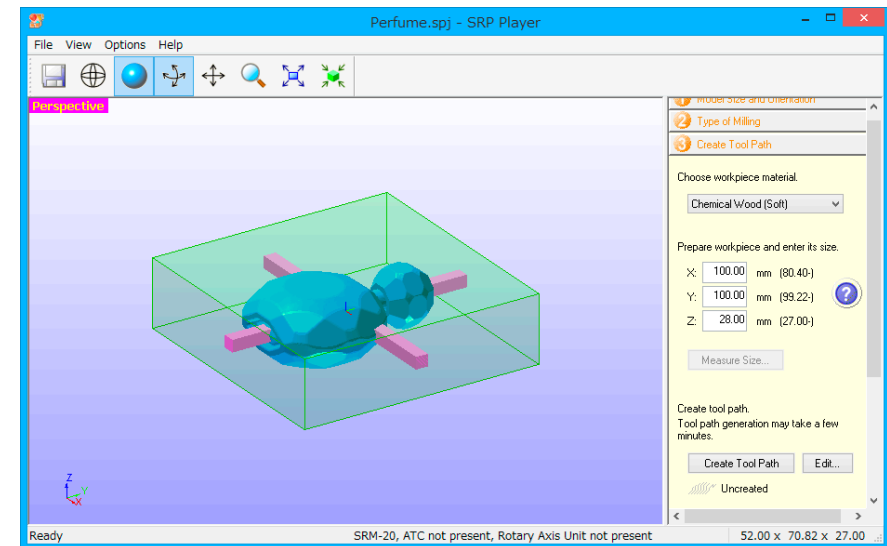

The main view displays the material shape according to the dimension values you have entered.





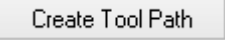

4. Create the cutting data (tool path).

Click  .

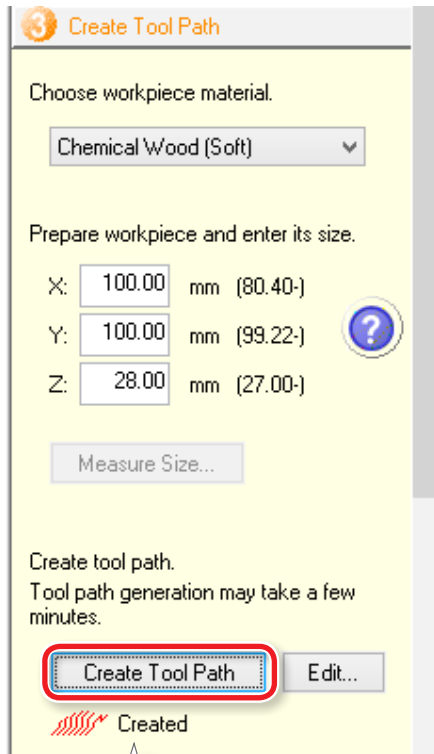
Once the cutting data (tool path) has been generated,  [Uncreated] changes to  [Created] under  .



MEMO

Clicking  allows you to change the detailed settings of the cutting data.

STEP 5 : Preview the Result of Cutting

You can display a 3D preview of the result of cutting for simulation. You can also check a rough guide for the time that it will take for cutting.

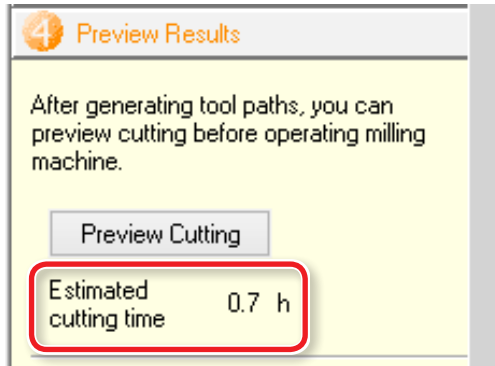

Procedure

1. Click **Preview Results**.

2. Click **Preview Cutting**.

The main view displays the preview.

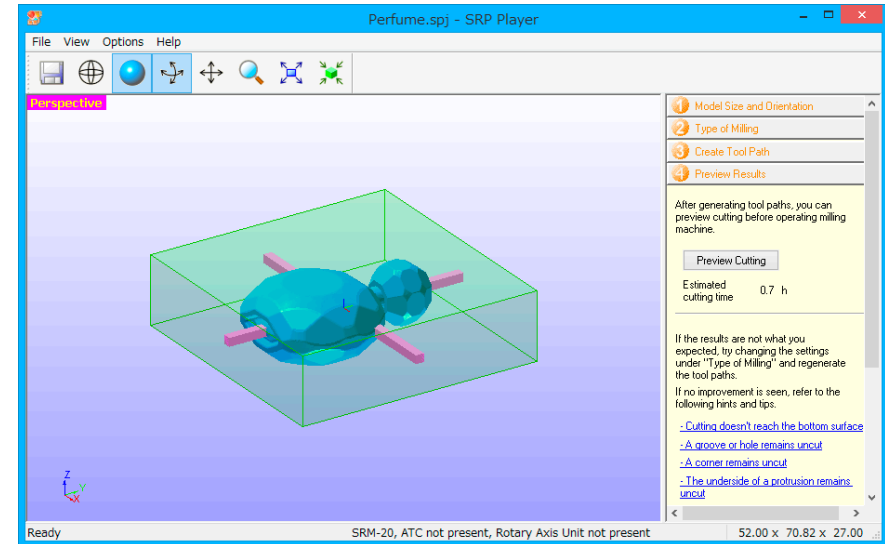

If the preview is satisfactory, proceed to **“Cutting”**.

☞ **“Cutting (Double Sided)”** (p. 41)

MEMO

You can save the cutting data by clicking **[File]** → **[Save As...]**.

Cutting (Double Sided)



STEP 1 : Set the Origin Point

Before you start cutting, you must set the origin point. When you cut with this machine, you need to set the X, Y, and Z origins.

☞ **"About Origin Point"** (p. 22)

Procedure

1. Attach the material to the scrap board.

* **Mark the location that will be the origin point of the material.**

MEMO

If you mount it in a position in the front, the work will be easier.

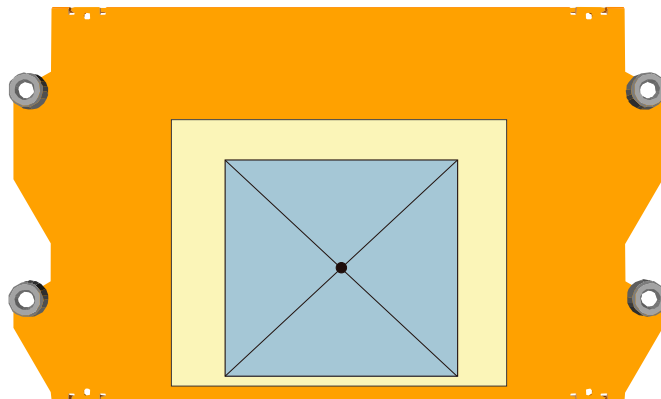

Front

2. Set the origin point to suite the material.

☞ **"STEP 3 : Set the Origin Point"** (p. 22)

Precautions to Take When Setting the Origin Point

* **Make sure to reset the Z origin point to suit the material.**

Failure to perform this operation may result in the cutting tool hitting the material, which may cause the material to come loose and damage the cutting tool.

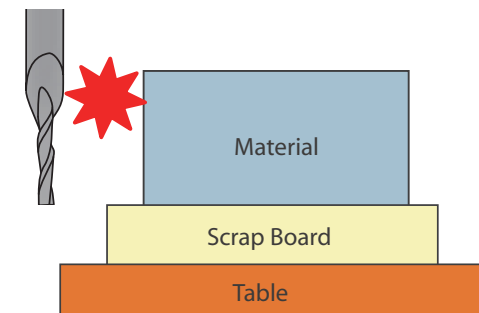
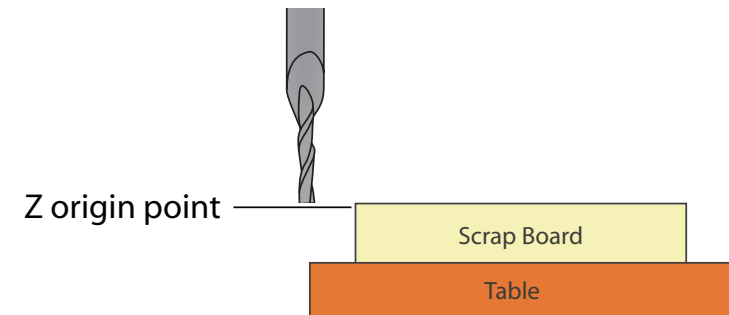



STEP 2 : Perform the Roughing

The points to be checked before cutting

Check the following thing before starting cutting. If there are problems with any of these, the cutting material may be wasted or the machine may be damaged.

- Is an output file right?
- Have you made a mistake with the origin point position?
- Do the cutting conditions match the type of cutting material?

To change the cutting tool for each process, replace the cutting tool before outputting data.

☞ **“STEP 5 : Attach the Cutting Tool”** (p. 11)



Procedure

1. Enable the [Rounding 1] process only on the SRP Player.

1-1. Open the  Create Tool Path pallet.

1-2. Click  .

1-3. Click the process you do not need.

1-4. Click  [Enable/Disable Cutting].

1-5. Repeat steps 1-3 and 1-4 to disable all the unnecessary processes.



Only the colored processes  will be output.

1-6. Click  .

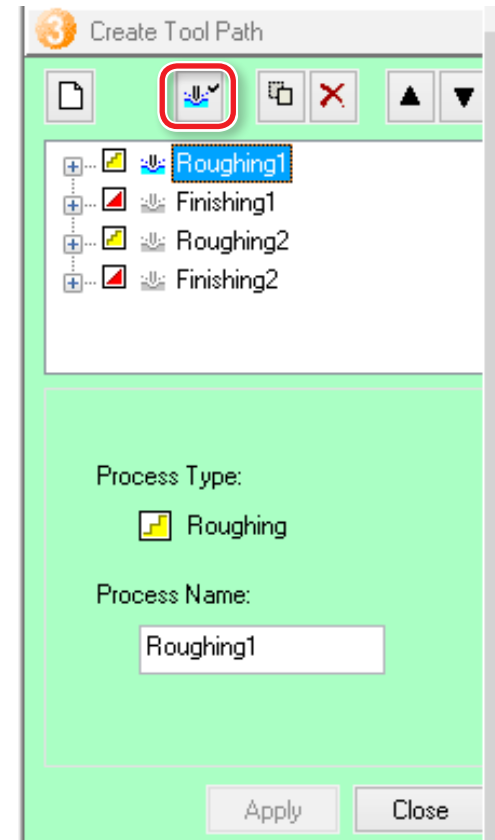

If there is no need to switch the cutting tool, it is possible to elect processes [Rounding 1] to [Finishing 2] and perform them all in a single operation.



2. Open the **Perform Cutting** pallet.

3. Click **Start Cutting...**.

4. Check if the cutting tool is installed as shown in the dialog and then click **Next >**.

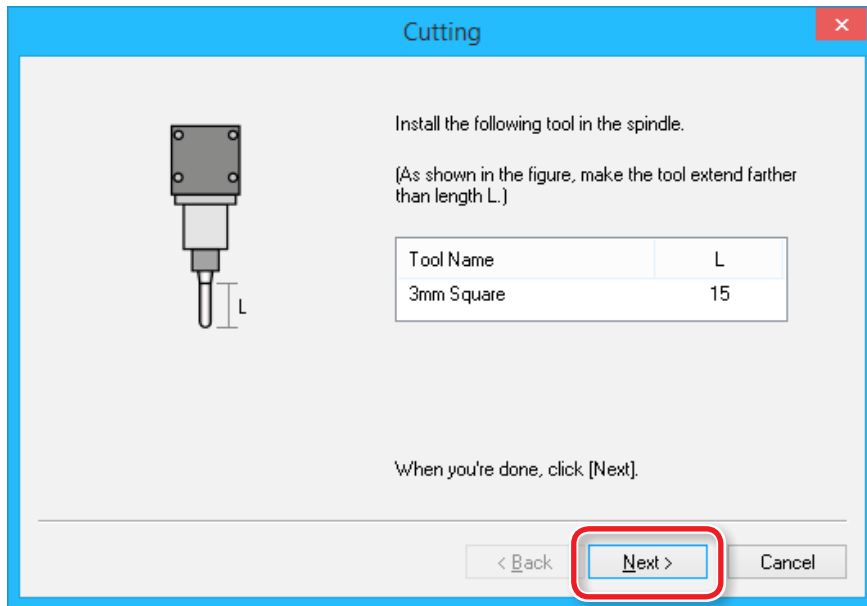

5. Select the top surface of the material and then click **Next >**.

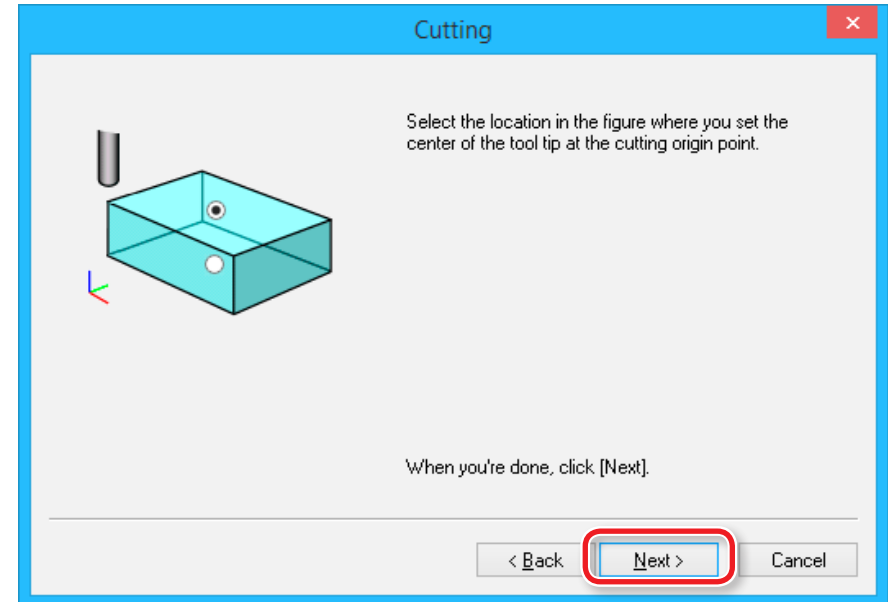

IMPORTANT

Before starting the cutting processes, double-check that the origin point exists on the top surface of the material. If the origin point is incorrectly positioned, the machine may fail to cut the workpiece as expected or break down.



6. Click **Next >**.

The machine begins cutting.

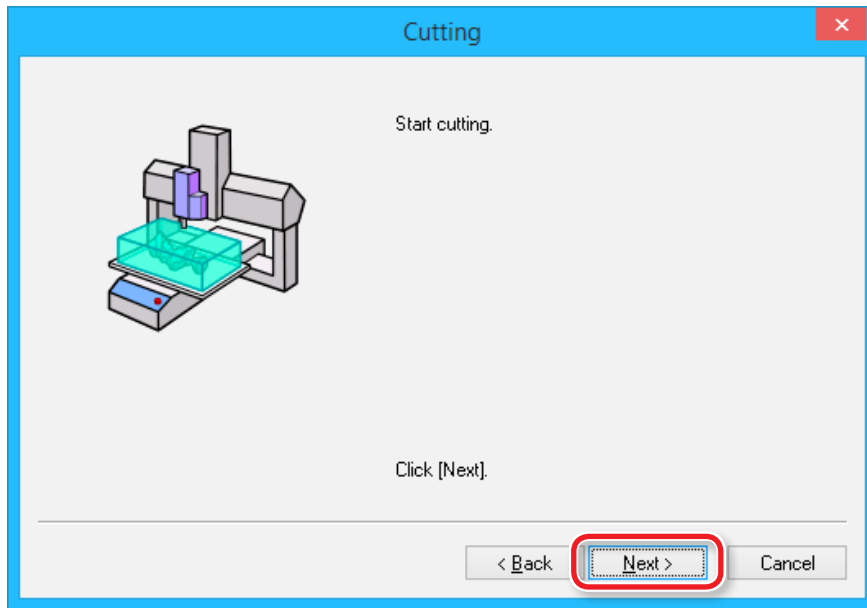

During cutting, you can adjust the spindle feed rate and speed using VPanel.

☞ User's Manual **"Adjusting the Feed Rate and Spindle Speed During Cutting"**

Clean the cutting waste constantly.

☞ **"Pausing / Resuming"** (p. 113)

A dialog appears that shows what is being output and the progress of cutting.

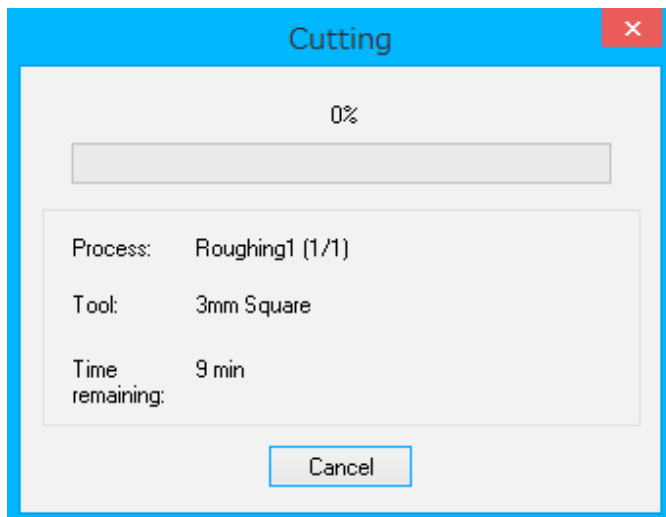



7. Click **Finish**.

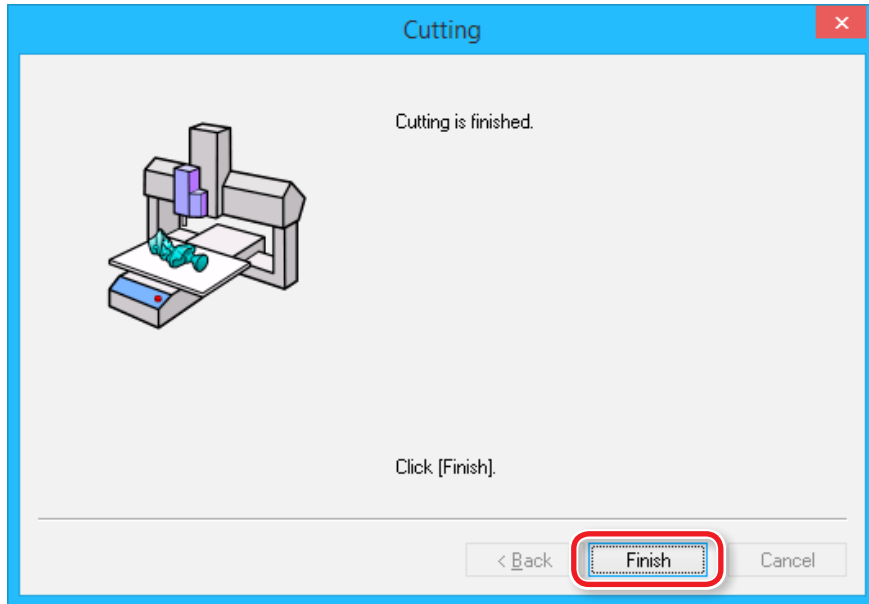



STEP 3 : Perform the Finishing

The points to be checked before cutting

Check the following thing before starting cutting. If there are problems with any of these, the cutting material may be wasted or the machine may be damaged.

- Is an output file right?
- Have you made a mistake with the origin point position?
- Do the cutting conditions match the type of cutting material?



To change the cutting tool for each process, replace the cutting tool before outputting data.

☞ **"STEP 5 : Attach the Cutting Tool"** (p. 11)

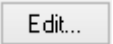

Procedure

1. Enable the **[Finishing 1]** process only on the SRP Player.

- 1-1. Open the  **Create Tool Path** pallet.
- 1-2. Click  .
- 1-3. Click the process you do not need.
- 1-4. Click  **[Enable/Disable Cutting]**.
- 1-5. Repeat steps 1-3 and 1-4 to disable all the unnecessary processes.



Only the colored processes  will be output.

- 1-6. Click  .

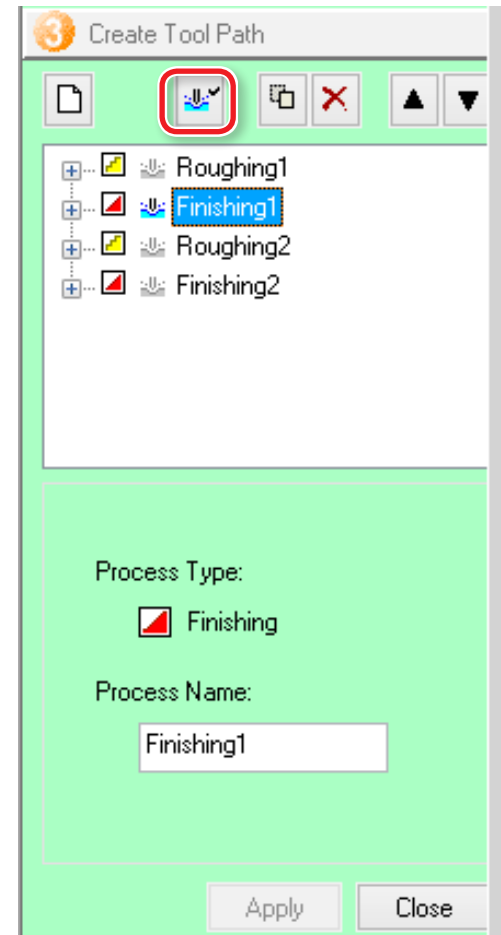

If there is no need to switch the cutting tool, it is possible to elect processes **[Roughing 1]** to **[Finishing 2]** and perform them all in a single operation.



2. Open the **Perform Cutting** pallet.

3. Click **Start Cutting...**.

4. Check if the cutting tool is installed as shown in the dialog and then click **Next >**.

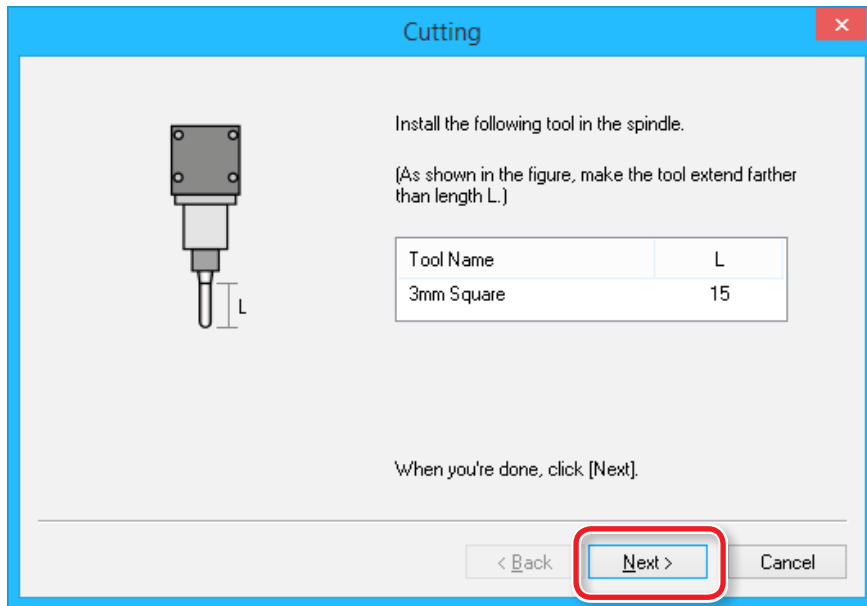

5. Select the top surface of the material and then click **Next >**.

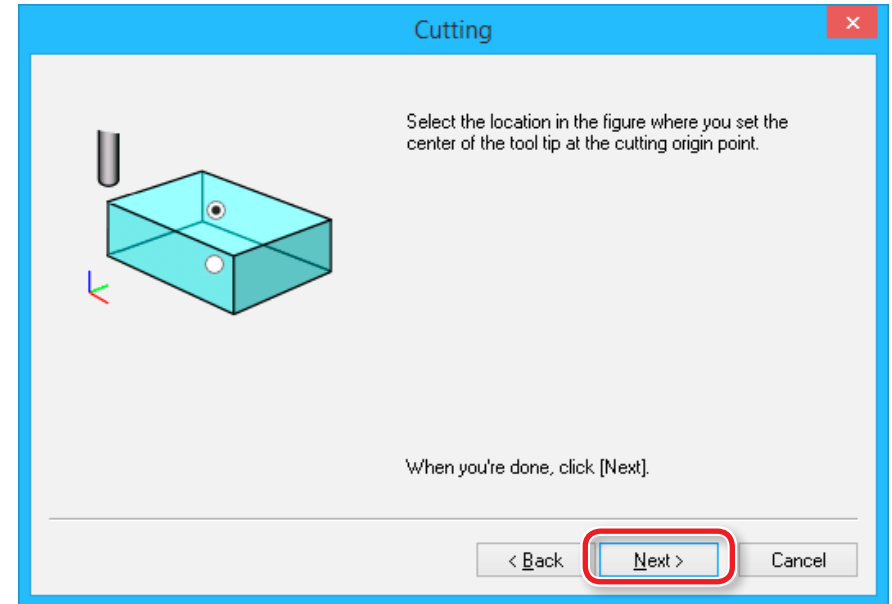

IMPORTANT

The finishing process requires you to use exactly the same origin point as you configured before the roughing process. Otherwise, you cannot perform cutting as you expect.



6. Click **Next >**.

The machine begins cutting.

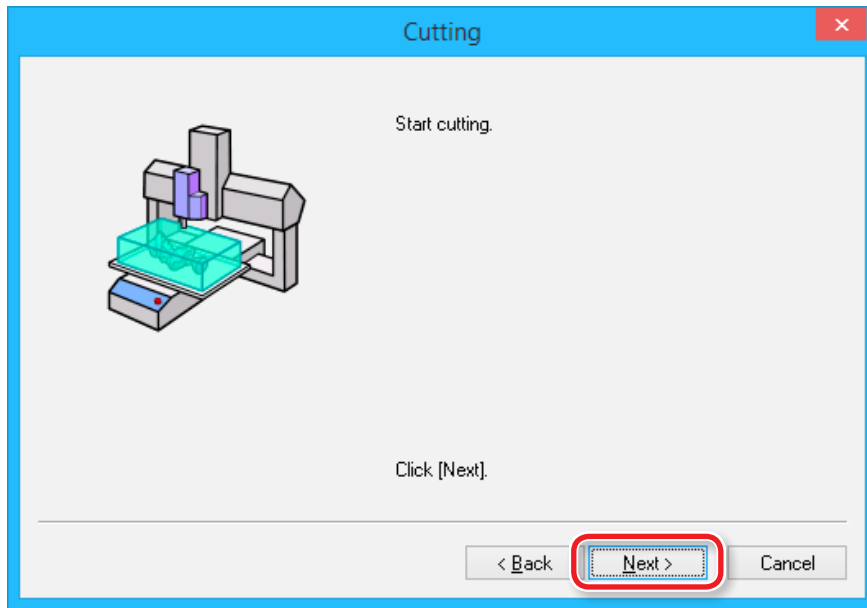

During cutting, you can adjust the spindle feed rate and speed using VPanel.

☞ User's Manual **"Adjusting the Feed Rate and Spindle Speed During Cutting"**

Clean the cutting waste constantly.

☞ **"Pausing / Resuming"** (p. 113)

A dialog appears that shows what is being output and the progress of cutting.

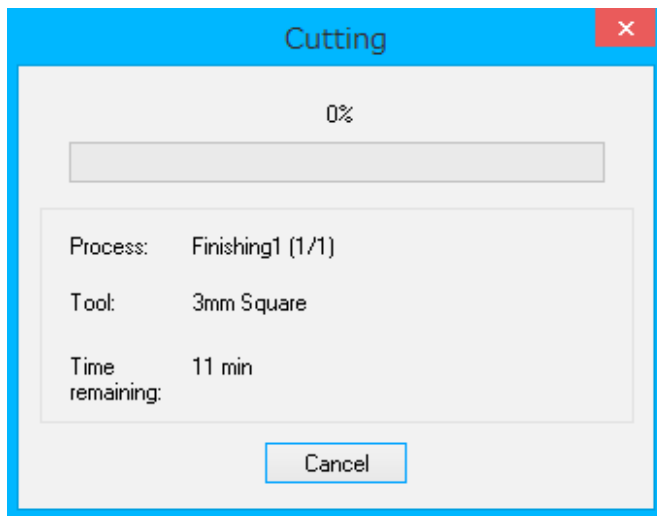



7. Click **Finish**.

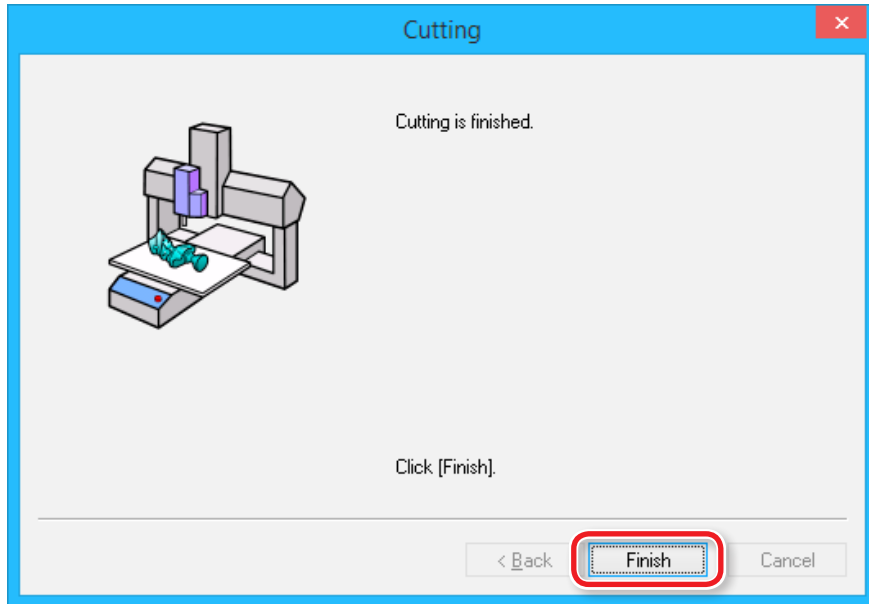

STEP 4 : Set the Drilling Process

Drilling

Several reversal methods can be used to cut both sides accurately in the same position. The procedure described in this section assumes that positioning pins are used to reverse the cutting material. The procedure involves drilling holes for inserting positioning pins.

Reversal process using positioning pins

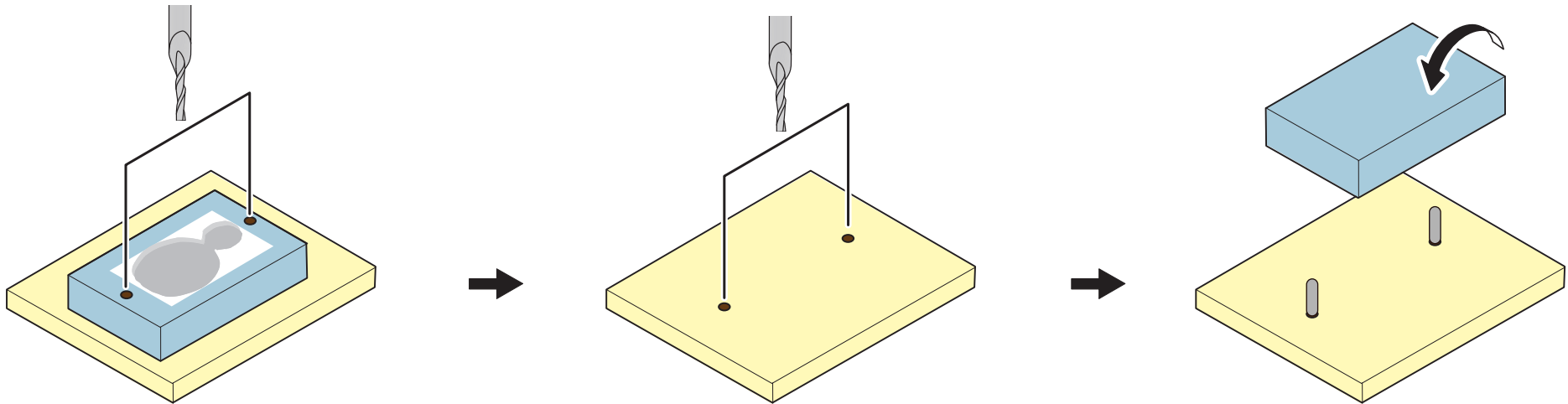



Procedure

1. Click the [View] button on the VPanel.

You may not be able to produce the desired product if the movement worsens during the process because of built up cutting waste. Keep an eye on how much cutting waste builds up and, if deemed necessary, remove the cutting waste that has built up around the X- and Z-axes. Also remove the cutting waste that has collected in the dust tray.

2. Change the cutting tool to [2 mm Square].

Before you can use a particular cutting tool, you need to register it.

☞ “STEP 4 : Register the Cutting Tool You Want to Use (when you are using SRP Player)” (p. 10)

☞ “When changing to a cutting tool with the same shank diameter” (p. 13)

3. Adjust the Z origin so that it fits the material while leaving the other origins intact.

3-1. Click the [-Z] feed button on VPanel to bring the tip of the cutting tool as close to the top surface of the material as possible.

3-2. Loosen the set screw of the machine and bring the tip of the cutting tool into contact with the top surface of the cutting material.

3-3. Using the set screw, fasten the cutting tool again.

3-4. Click [Z] of set origin point on the VPanel.

Set the Z origin alone, referring to steps 2 to 5 in “STEP 3 : Set the Origin Point” (p. 22)

*Failure to do so could cause the material to collide with the cutting tool, possibly leading to the breakage of the cutting tool or the inability to drill a hole with the intended depth.



4. On the menu bar of SRP Player, click [Options] → [Hole...].

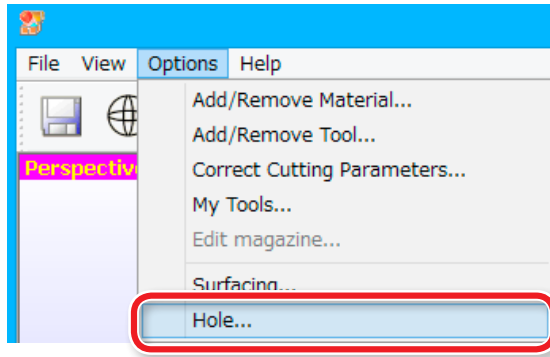

5. Configure the positioning pin diameter, the number of holes, and other settings as appropriate.

This example assumes that the following options are configured:

- Pin Diameter : 3 mm
- Adjust Hole Diameter : Set the slider to [Pin Dia.].
- No. of Holes : 2
- Depth : 5 mm
- Tool : 2 mm Square
- Material : Chemical Wood (Soft)
- Cutting Direction : Up Cut

When you are done, click  .

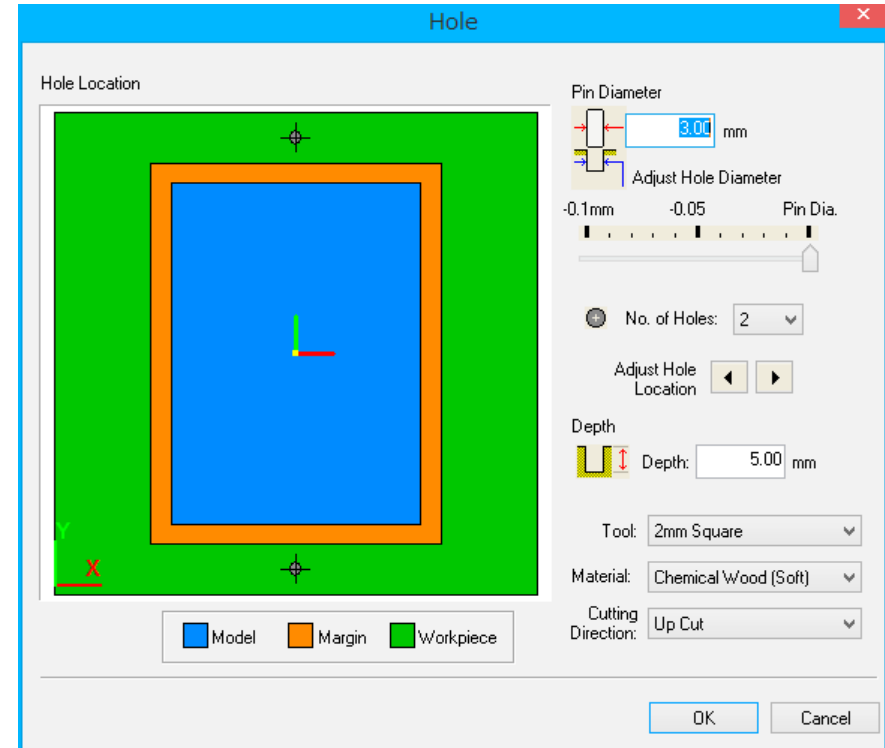

IMPORTANT

For [Material], select the same material as selected on the

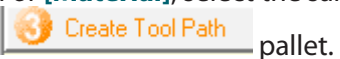

Selecting a wrong material would result in failure to correctly drill holes.



6. Click **Start Drilling**.

The machine begins drilling.

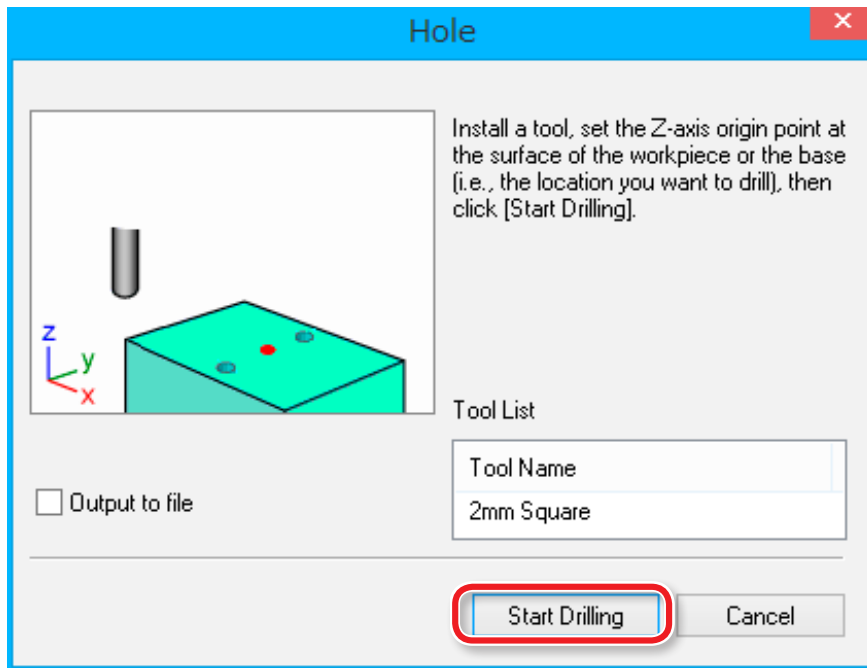

A dialog appears that shows what is being output and the progress of drilling.

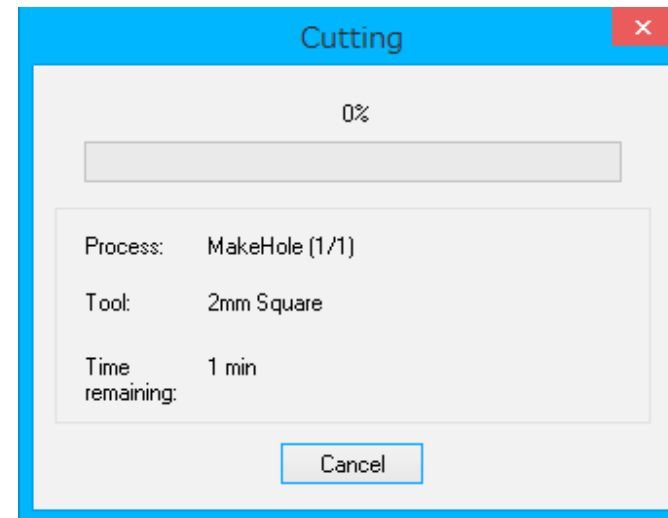

STEP 5 : Drill the Scrap Board

Drill the scrap board to create holes in the same positions as you drilled the material.

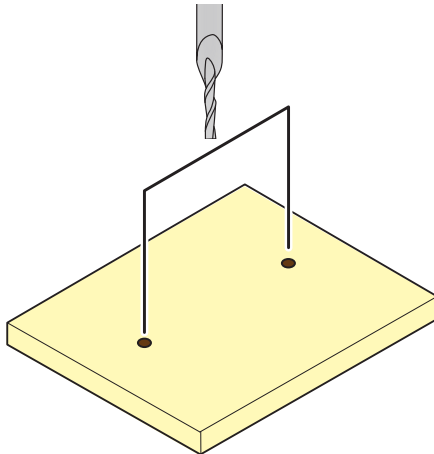

Procedure

1. Click the **[View]** button on the VPanel.



 You may not be able to produce the desired product if the movement worsens during the process because of built up cutting waste. Keep an eye on how much cutting waste builds up and, if deemed necessary, remove the cutting waste that has built up around the X- and Z-axes. Also remove the cutting waste that has collected in the dust tray.

2. Remove the cutting waste and remove the material.

Remove the double-stick tape on the back of the material.

 When material cannot remove finely, it removes using wooden spatulas etc.



3. Make a mark on the material to ensure that you do not confuse the side to be reversed.

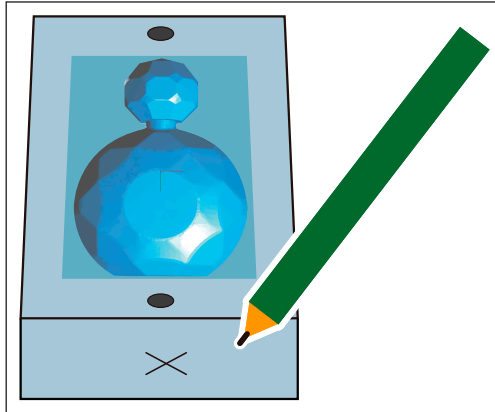

4. Adjust the Z origin so that it fits the scrap board while leaving the other origins intact.

- 4-1. Click the [-Z] feed button on VPanel to bring the tip of the cutting tool as close to the top surface of the scrap board as possible.
- 4-2. Loosen the set screw of the machine and bring the tip of the cutting tool into contact with the top surface of the scrap board.
- 4-3. Using the set screw, fasten the cutting tool again.
- 4-4. Click [Z] of set origin point on the VPanel.

Set the Z origin alone, referring to steps 2 to 5 in **“STEP 3 : Set the Origin Point”** (p. 22).

* Failure to do so would cause the cutting tool not to reach the scrap board, being unable to cut it.

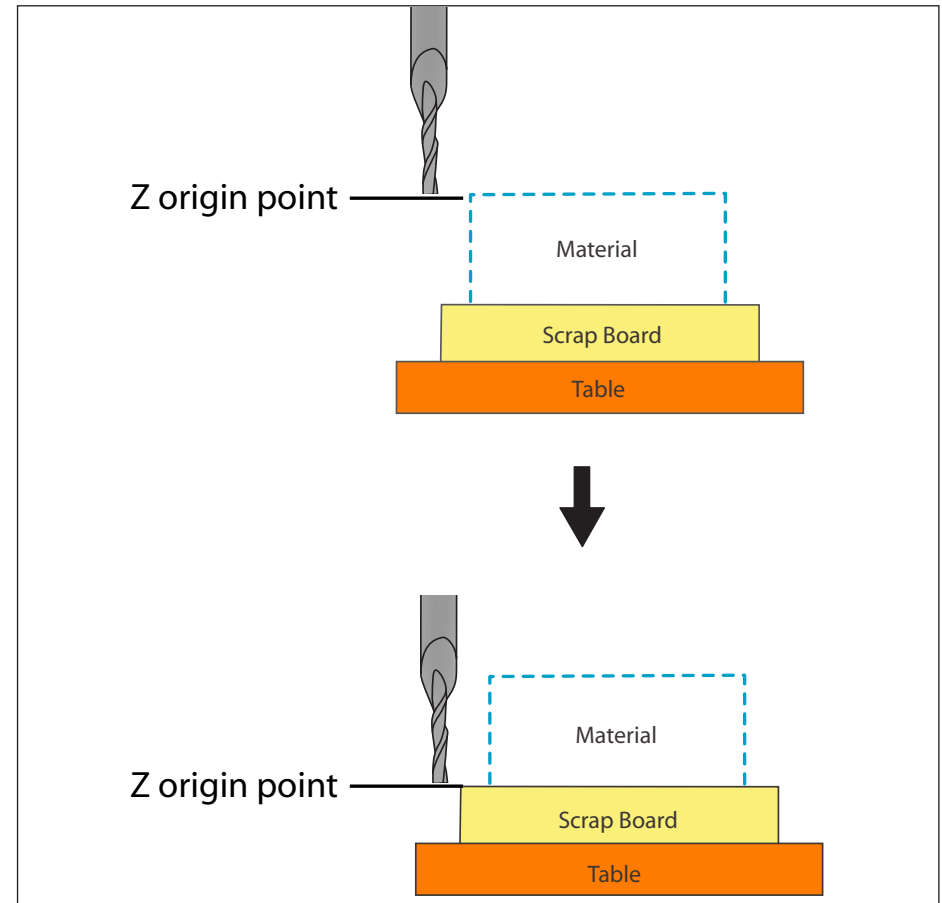



5. On the menu bar of SRP Player, click [Options] → [Hole...].

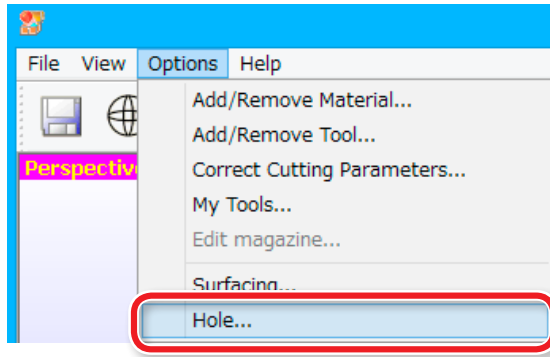

6. Configure the positioning pin diameter, the number of holes, and other settings as appropriate.

This example assumes that the following options are configured:

- Pin Diameter : 3 mm
- Adjust Hole Diameter : Set the slider to [Pin Dia.].
- No. of Holes : 2
- Depth : 5 mm
- Tool : 2 mm Square
- Material : Chemical Wood (Soft)
- Cutting Direction : Up Cut

When you are done, click  .

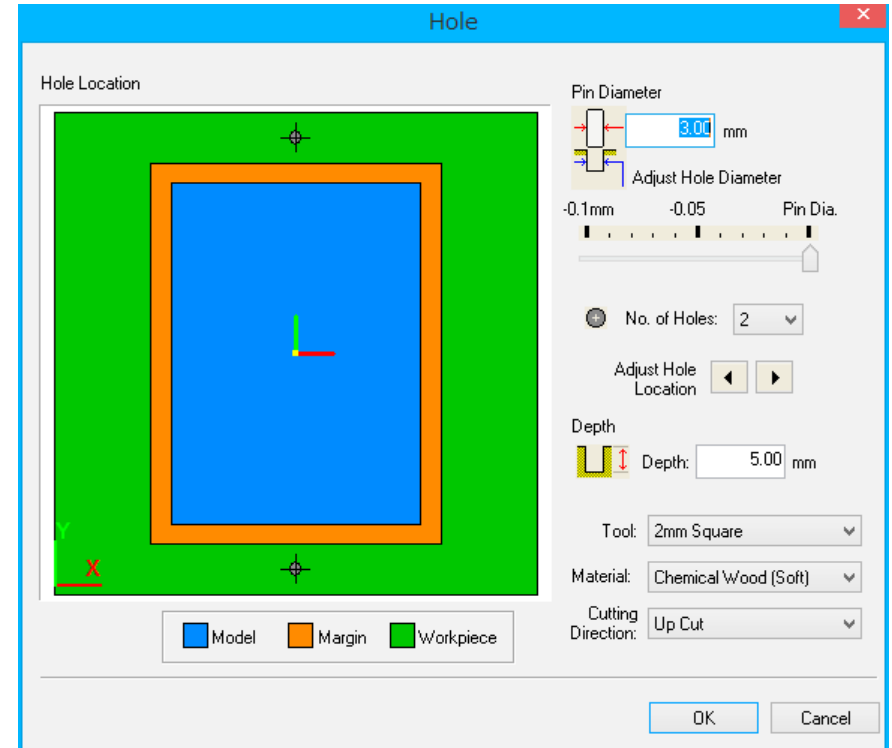



7. Click **Start Drilling**.

The machine begins drilling.

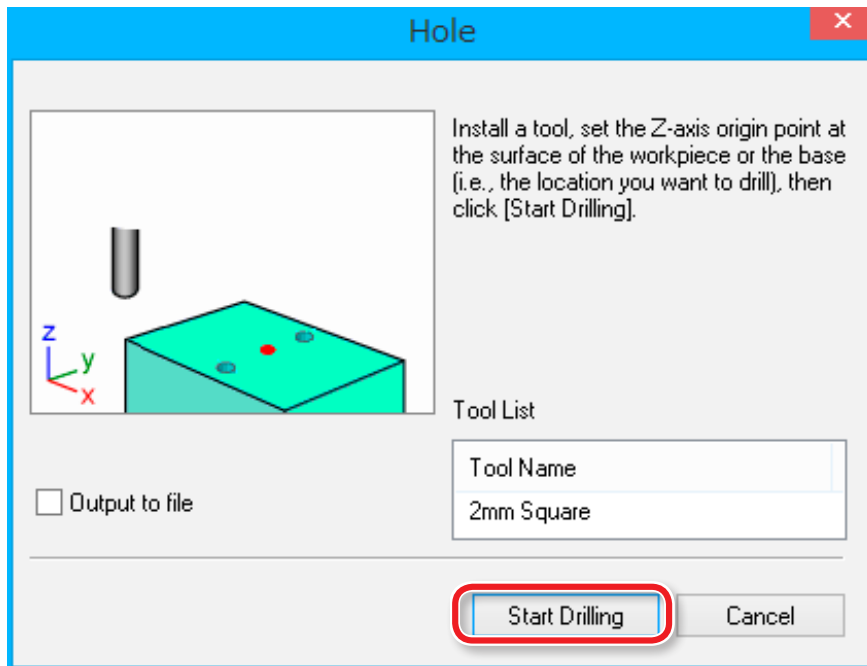

A dialog appears that shows what is being output and the progress of drilling.

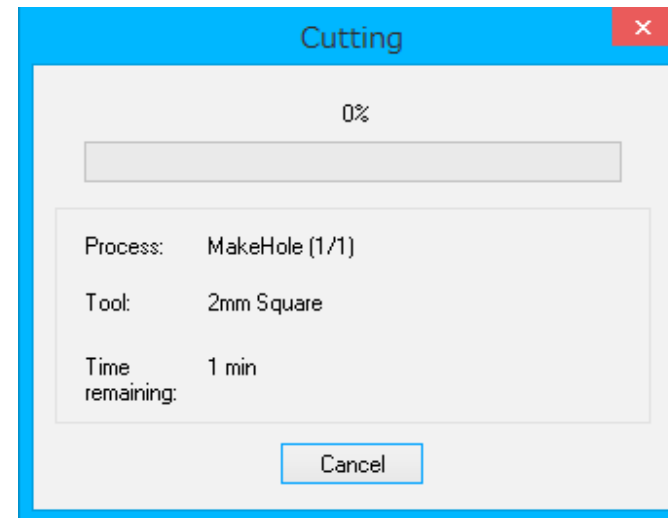

STEP 6 : Reverse the Material

Fix the material reversed using the positioning pin.

☞ **“Reversal process using positioning pins”** (p. 52)

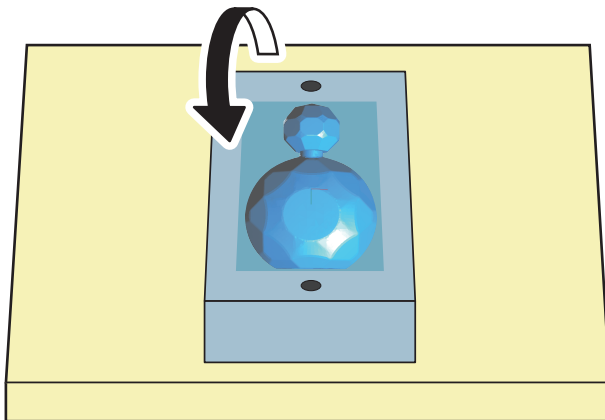
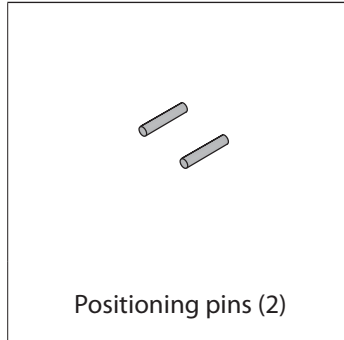

1. Click the [View] button on the VPanel.



You may not be able to produce the desired product if the movement worsens during the process because of built up cutting waste. Keep an eye on how much cutting waste builds up and, if deemed necessary, remove the cutting waste that has built up around the X- and Z-axes. Also remove the cutting waste that has collected in the dust tray.

2. Remove the cutting tool **“2 mm Square.”**

☞ **“When changing to a cutting tool with the same shank diameter”** (p. 13)



3. Insert the positioning pins to the scrap board.

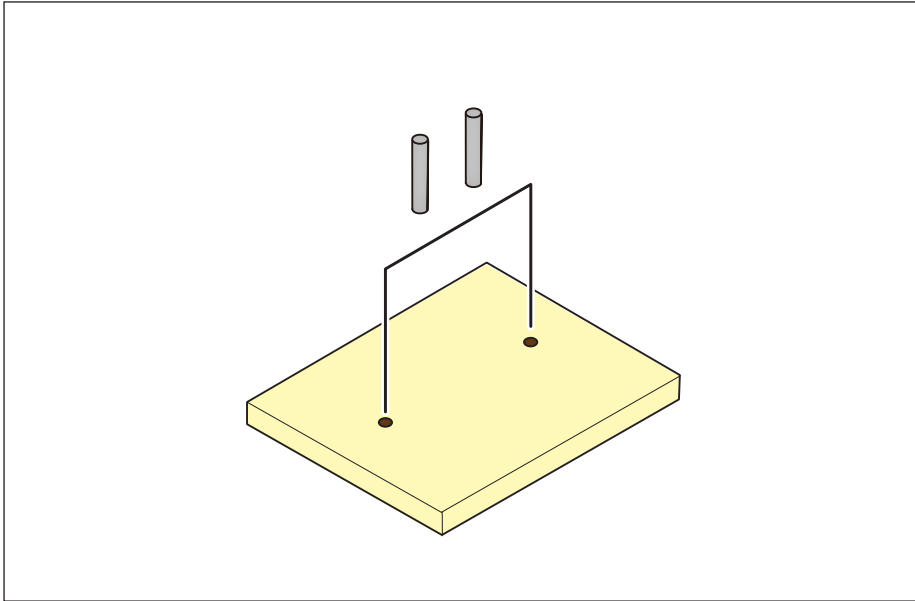

4. Affix double-sided tape to open areas of the top surface of the material.

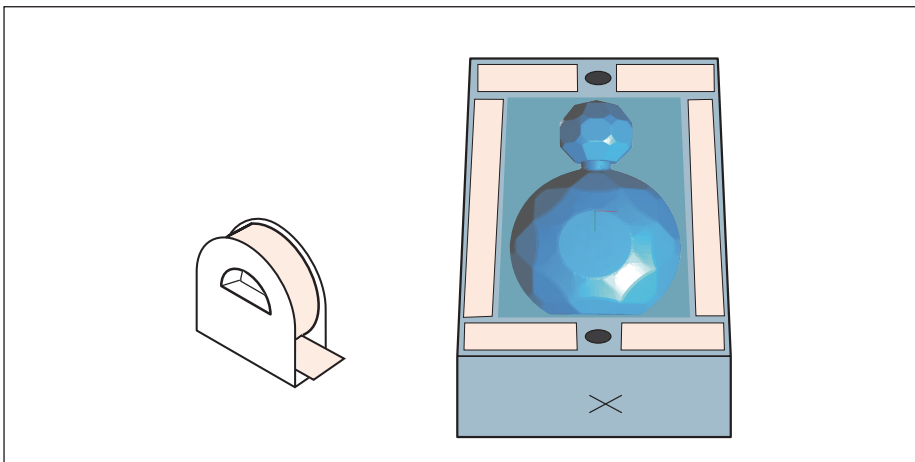

5. Rotate the material 180° toward you around the X axis and align the pins with the holes in the material.

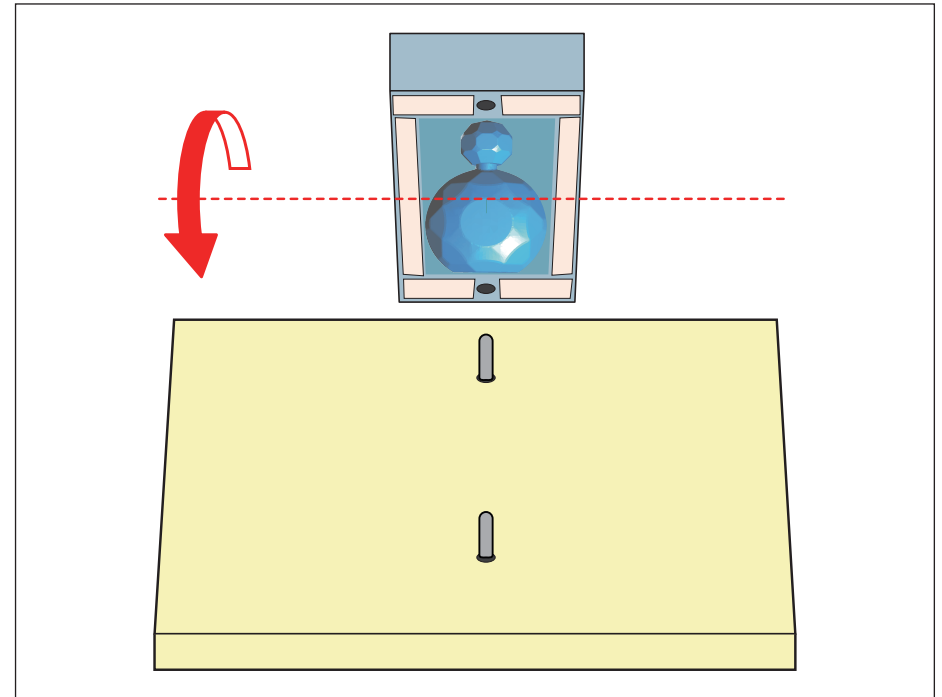



6. Presses down from top and fixes firmly.

The side with the mark is the back.

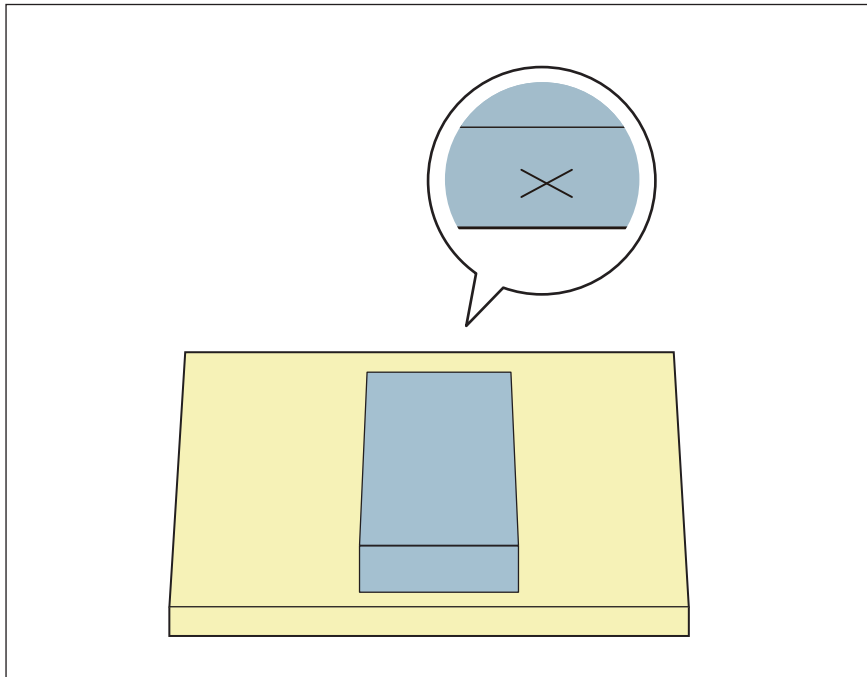

7. Replace a cutting tool to [3 mm Square].

☞ "When changing to a cutting tool with the same shank diameter" (p. 13)

STEP 7 : Cut the Bottom Surface

1. Adjust the Z origin so that it fits the material while leaving the other origins intact.

- 1-1. Click the [-Z] feed button on VPanel to bring the tip of the cutting tool as close to the top surface of the material as possible.
- 1-2. Loosen the set screw of the machine and bring the tip of the cutting tool into contact with the top surface of the cutting material.
- 1-3. Using the set screw, fasten the cutting tool again.
- 1-4. Click [Z] of set origin point on the VPanel.

Set the Z origin alone, referring to steps 2 to 5 in "STEP 3 : Set the Origin Point" (p. 22).

*Failure to do so could cause the material to collide with the cutting tool, possibly leading to the detachment of the material or the breakage of the cutting tool.

2. Cut the bottom surface, referring to the procedure for cutting the top surface.

"STEP 2 : Perform the Roughing" (p. 42)

"STEP 3 : Perform the Finishing" (p. 47)

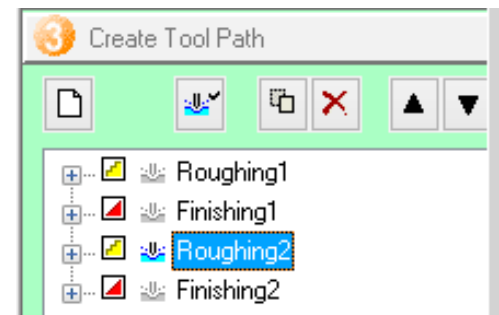

STEP 8 : Remove the Cut Material

MEMO

Depending on the settings configured on VPanel, the power may automatically turn off when a certain period of time elapses with the machine idle*.

* **“Idle”** means the state in which the movement of the table and spindle head is stopped (except when a cutting process is paused).

☞ User’s Manual **“Power Option”**

Procedure

1. Click [View] of VPanel.



2. Remove the cutting waste and remove the material.

Remove the double-stick tape on the back of the material.



When material cannot remove finely, it removes using wooden spatulas etc.

3. Remove the support parts.



STEP 9 : Turning the Power Off

Push [⏻] (Power) button.

A LED lamp lights off. After cutting, clean the cutting waste certainly.

☞ User's Manual **"Cleaning after Cutting Operation Ends"**

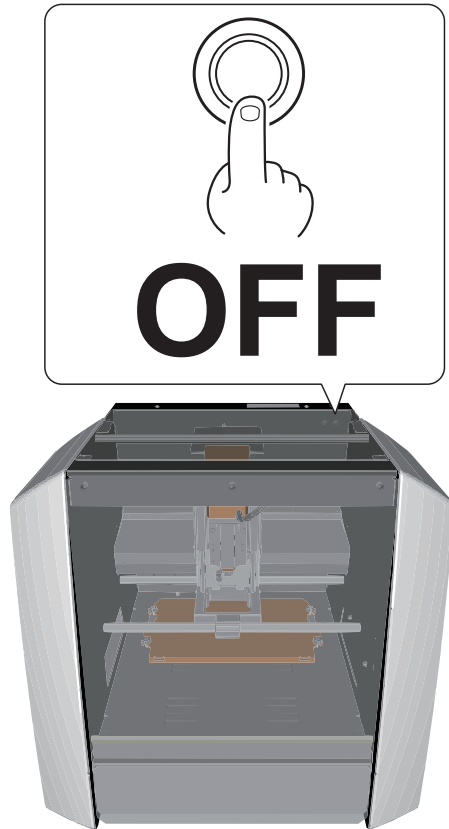

Guide for Cutting with MODELA Player 4

The Flow of Double-Sided Cutting 66

The Flow of One Side Cutting 66

Items Necessary for Cutting 67

Items to Prepare Yourself..... 69

Creating a MODELA Player 4 File..... 70

STEP 1: Load the Cutting Data..... 70

STEP 2 : Set the Machine Selection 70

STEP 3 : Set the Origin Point of the Model
and Orientation 71

STEP 4 : Set the Material..... 72

STEP 5 : Set the Number of Cutting Surfaces 72

STEP 6 : Set the Margin..... 73

STEP 7 : Set the Surface leveling Process of the Scrap Board . 74

STEP 8 : Confirm the Cutting Preview 81

STEP 9 : Set the Surface leveling Process
of the Material 83

STEP 10 : Set the Roughing Process..... 88

STEP 11 : Set the Finishing Process 93

STEP 12 : Set the Drilling Process 97

STEP 13 : Set the Bottom Surface Process 103

Cutting (Double Sided) 105

STEP 1 : Attach the Material to the Scrap Board 106

STEP 2 : Set the Origin Point..... 108

STEP 3 : Perform the Surface Leveling of the Scrap Board... 112

STEP 4 : Perform the Surface Leveling of the Material. 115

STEP 5 : Perform the Roughing 116

STEP 6 : Perform the Finishing 118

STEP 7 : Perform the Drilling in the Material..... 120

STEP 8 : Perform the Drilling in the Scrap Board 122

STEP 9 : Reverse the Material 123

STEP 10 : Cut the Bottom Surface..... 126

STEP 11 : Remove the Cut Material 126

STEP 12 : Turning the Power Off 127

The Flow of Double-Sided Cutting

The Flow of One Side Cutting

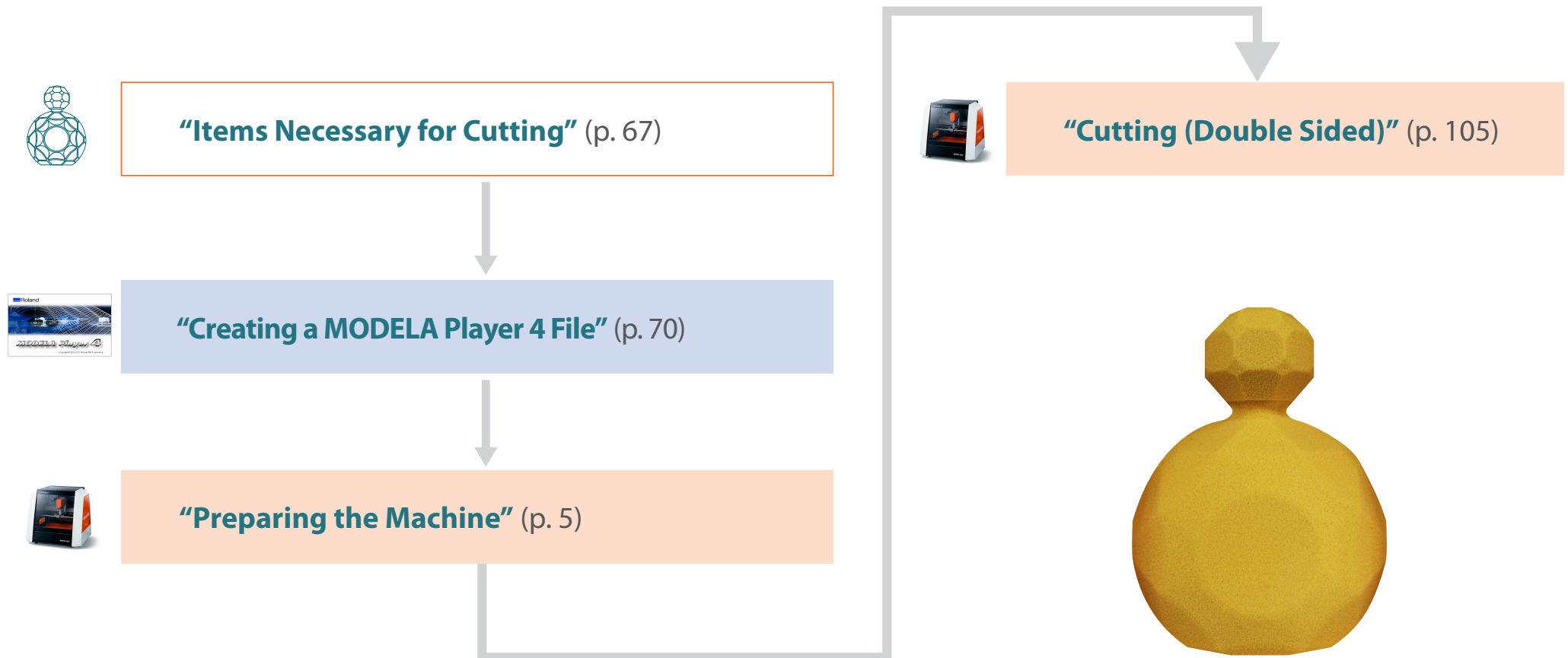

In this manual, a procedure is explained by the method using "Perfume.stl." If it does as a procedure, it can cut, as shown in the following figure.







Items Necessary for Cutting

Software Applications Necessary for Sample Cutting

☞ Download "<http://startup.rolanddg.com>"

 <p>MODEL A Player 4</p> <p>☞ User's Manual "About MODEL A Player 4"</p> <p>☞ "Cutting (Double Sided)" (p. 105)</p>	 <p>Virtual MODEL A</p>
--	--

Machine Accessories Necessary for Sample Cutting

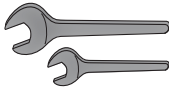
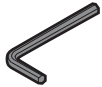
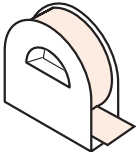
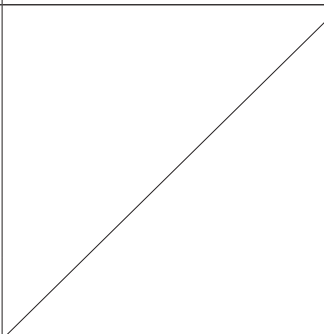
 <p>Collet (1)</p>	 <p>Cutting tool (1)</p>	 <p>Set screw (1)</p>	 <p>Positioning pin (2)</p>
 <p>Spanner L / S (one for each)</p>	 <p>Hexagonal wrench, small (1)</p>	 <p>Double-stick tape (1)</p>	



Sample Cutting Data

Installation of MODELA Player 4 will also install sample data together.
(When the installation place of MODELA Player 4 is Drive C)

C:\ProgramData\Roland DG Corporation\MODELA Player 4\Sample

“Perfume.stl” Data Size

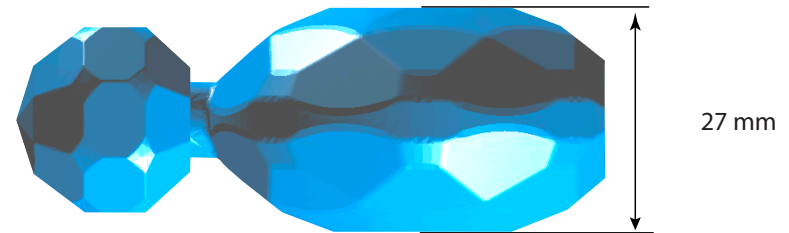
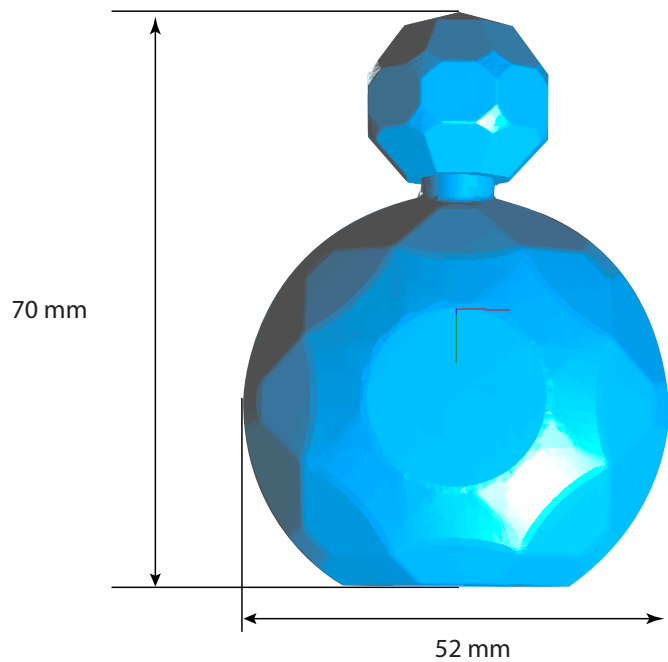



Items to Prepare Yourself

*The dimensions below are a reference size for the sample. This manual lists the values when a material and a scrap board with the following dimensions have been prepared.

Material

Make sure that the material is larger than the size specified in the data. At the same time, taking into account the size of the scrap board that will be used, make sure that the material is small enough to fall within the cutting range of this machine. Too large a size could result in collision with moving parts, possibly leading to the breakage of the material or jig or other failure.

☞ User's Manual **"Cutting Area"**

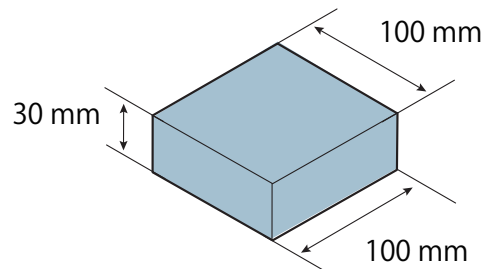

The data size can be set for the size of the material.

☞ **"Set the Size of Cutting Data"** (p. 71)

Scrap Board

A scrap board is a board that is placed under the material when cutting it so that the table is not cut.

Ensure that the scrap board is larger than the material and is of a size that can be affixed to the table (150 x 200 mm). When performing double-sided cutting using the positioning pins, the thickness of the scrap board must be at least 6 mm.

☞ **"Reversal process using positioning pins"** (p. 97)

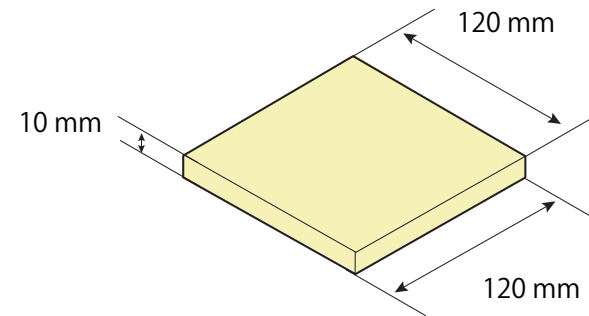

Others

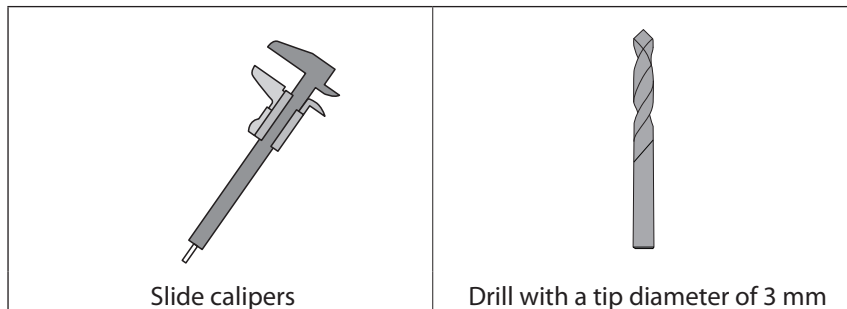

*The drill will be used in "STEP 7 : Perform the Drilling in the Material" (p. 120). Alternatively, you can use the cutting tool that comes with the machine.

STEP 1: Load the Cutting Data

You can import a file in IGES, DXF (3D), STL, or MODELA Player (Ver. 3 or later) format.

☞ **“Sample Cutting Data”** (p. 68)

Procedure

1. Start MODELA Player 4.

☞ User's Manual **“Start MODELA Player 4”**

2. Click [File] - [Open], and open **“Perfume.stl”**

C:\ProgramData\Roland DG Corporation\MODELA Player 4\Sample
(When the installation place of MODELA Player 4 is Drive C)

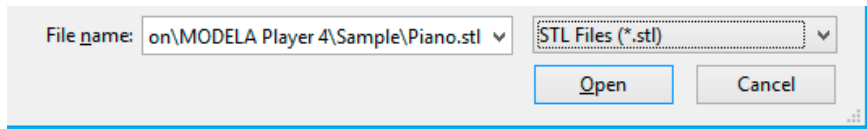

STEP 2 : Set the Machine Selection

IMPORTANT

Unless a machine setup is performed, a right setup or output cannot be performed.

Procedure

1. Click [File] - [Select Machine].

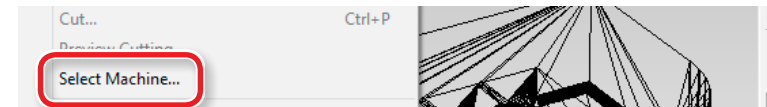

2. Set the machine selection.

2-1. Model Name : **[SRM-20]**

2-2. Command Set : **[RML-1]** Spindle Unit : **[Standard]**

2-3. Printer Name : **[Roland SRM-20]**

2-4. Click **[OK]**.

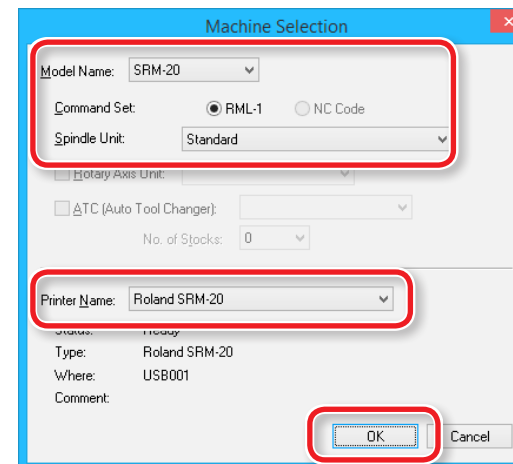

STEP 3 : Set the Origin Point of the Model and Orientation

☞ User's Manual "Origin point of the Model / Origin point"

Procedure

1. Click  [Model].

2. Set [Selected Top Surface].

"Perfume.stl": Following figure → [OK]

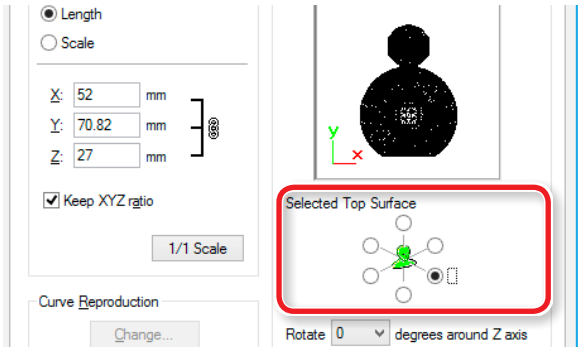

3. Set the origin point of the model.

Click the "Origin" tab, select the origin position.

"Perfume.stl" : Center of the model → [OK]

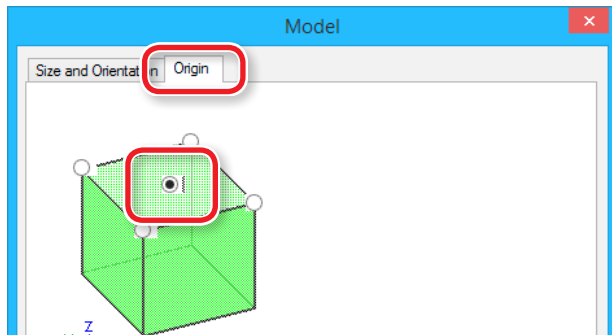

Set the Size of Cutting Data

Click  [Model].

Input the "Model Size" values to change the size.

Click [1/1 Scale] to return to the original size.

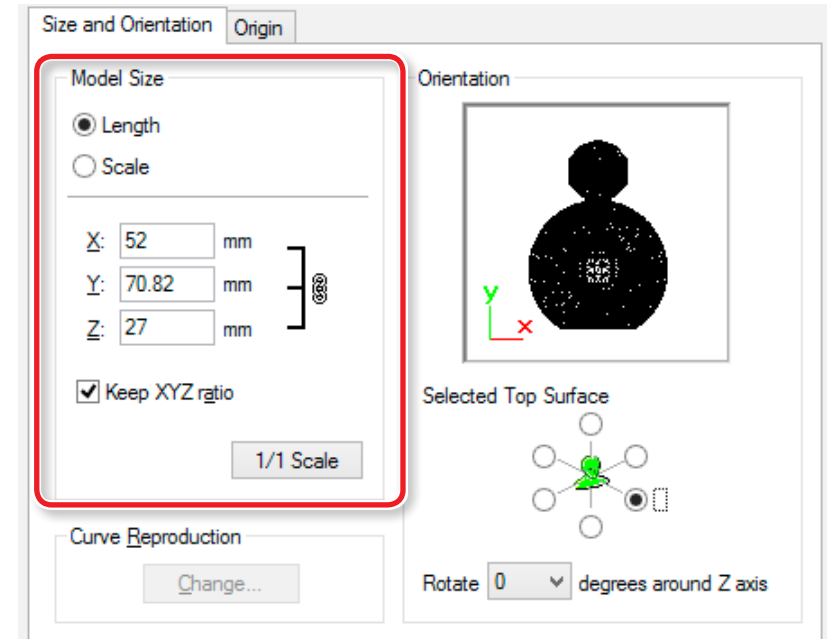

The size of cutting data can be checked at the lower right of the main screen.

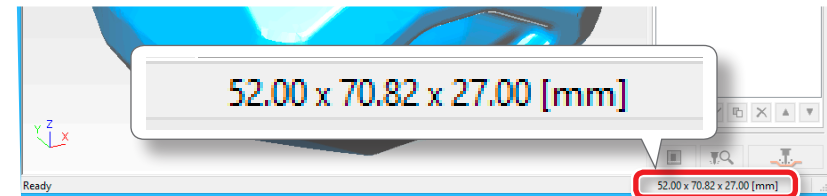

STEP 4 : Set the Material

Select the quality of the material. Set the type of prepared material.

☞ User's Manual **"Material Types"**

Select the material.

Choose a workpiece material from the pull-down list.

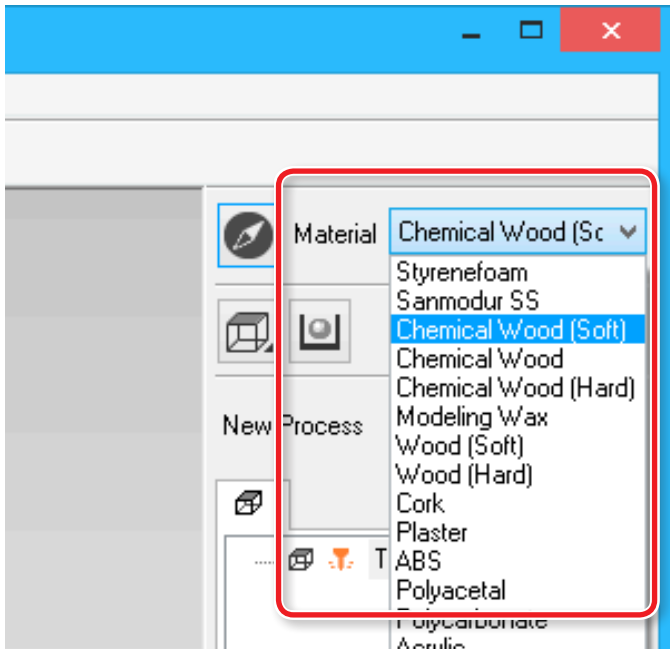

MEMO

Set up the quality of the material before process creation. Because changing the composition also produces changes in the cutting tool and the cutting parameters, changing the composition after you have created the processes is not recommended.

STEP 5 : Set the Number of Cutting Surfaces

Click  **[Cutting Surfaces]**, select number of cutting surfaces.

"Perfume.stl" :  (Double sided cutting)

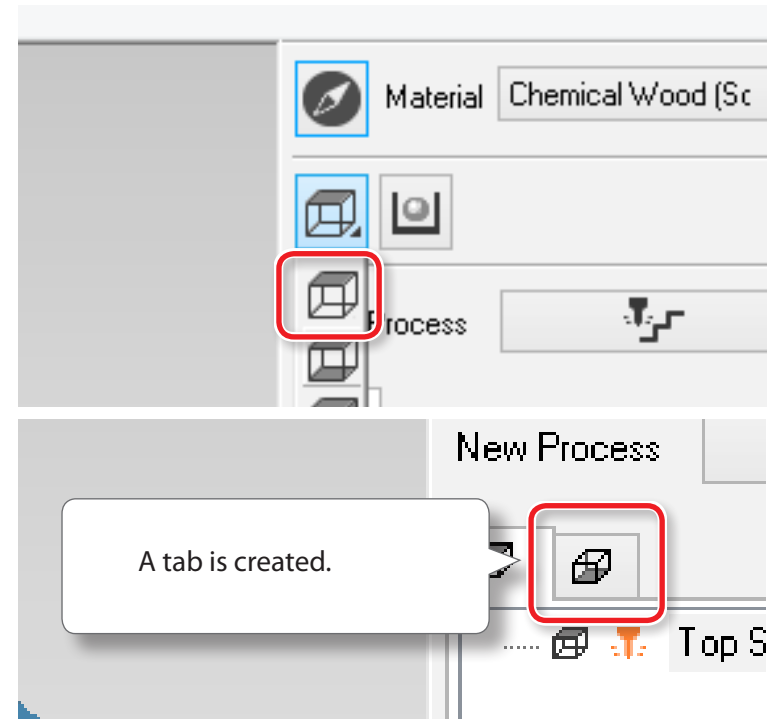

One sided cutting (Only top surface)



Double sided cutting (Top surface/Bottom surface)



Three- or four-sided cutting (Top/Bottom/Front/Rear)

STEP 6 : Set the Margin

Make settings for the space around the model to provide approach paths for the cutting tool.

☞ User's Manual **"The Cutting Area is Different Depending on the Margin Settings"**

Procedure

1. Click  [Modeling Form].

2. Select the margin setting.

"Perfume.stl" : [Automatic] → [OK]

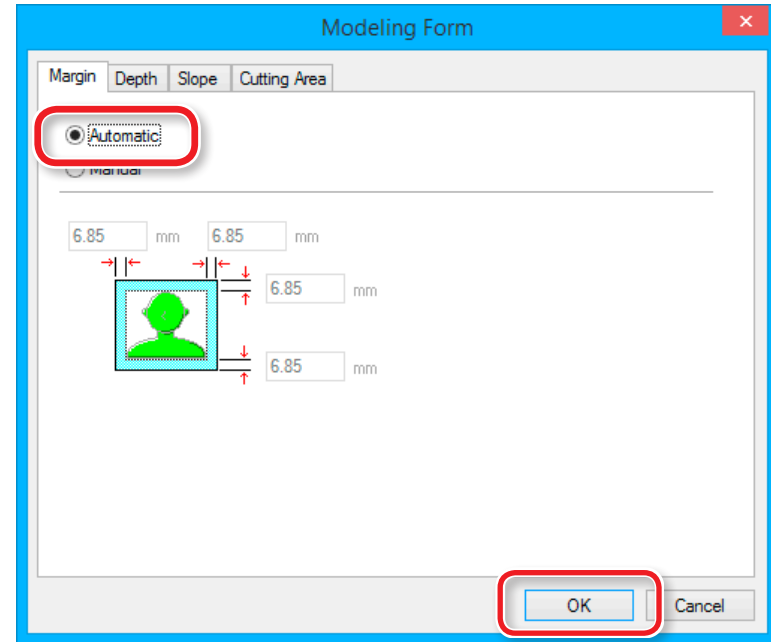

[Automatic]

Sets a front and rear, right and left margin of 6.85 mm.

[Manual]

Enter the desired margin space.

STEP 7 : Set the Surface leveling Process of the Scrap Board

Surface leveling of Scrap Board

In the case you use a scrap board for double-sided cutting, the first step is to level the scrap board surface. You have not only to level the material surface but also level the scrap board surface; this is required to make the top and bottom surfaces of the material parallel with the cutting plane along which the cutting tool moves. By leveling the surface of the scrap board that will be attached to the table on the machine, you can create a work plane that is parallel with the cutting plane along which the cutting tool moves.

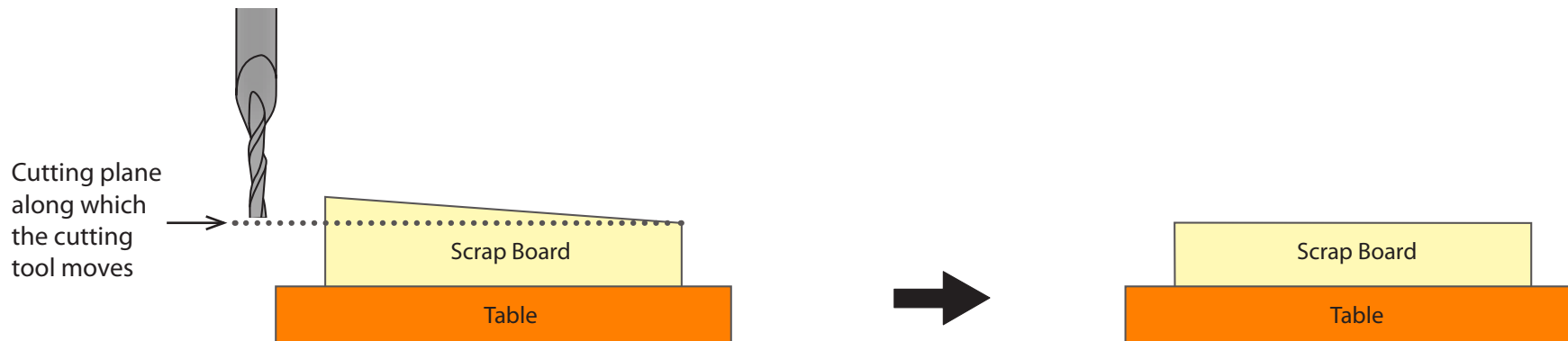



Procedure

1. Create the surface leveling process of the scrap board.

Select the top surface, then click  [New Process].

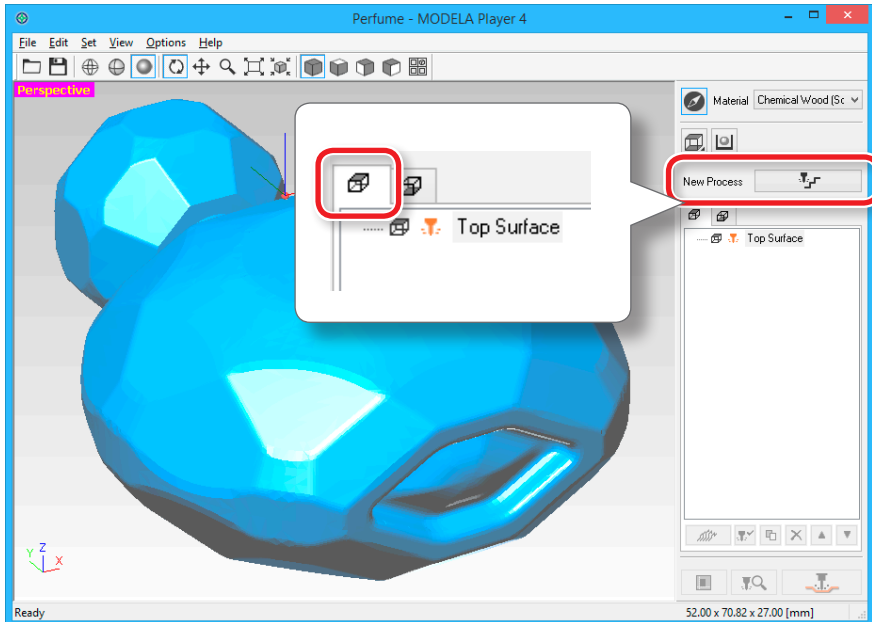

2. Set the type of process.

Select [Surfacing], then click [Next].

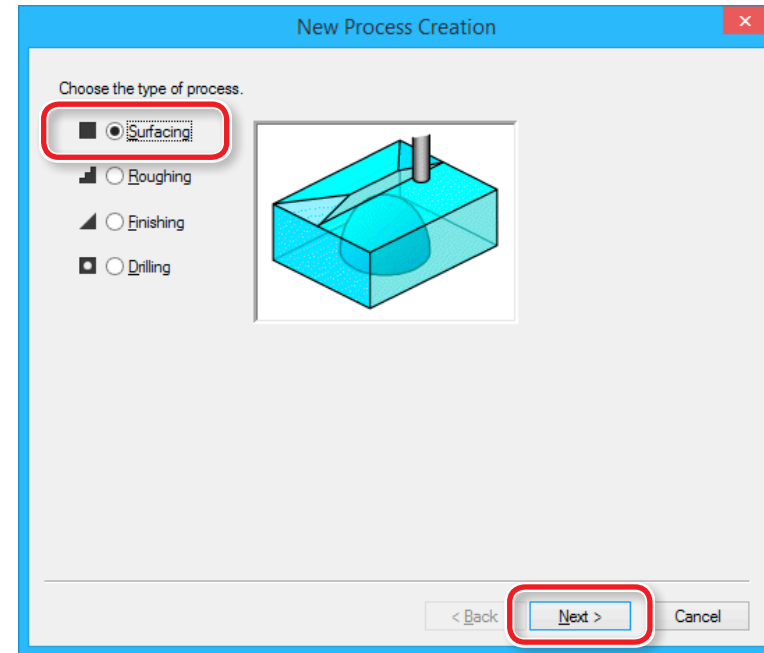



3. Confirm the cutting surface.

Check that [Top[+Z]] is selected and click [Next].

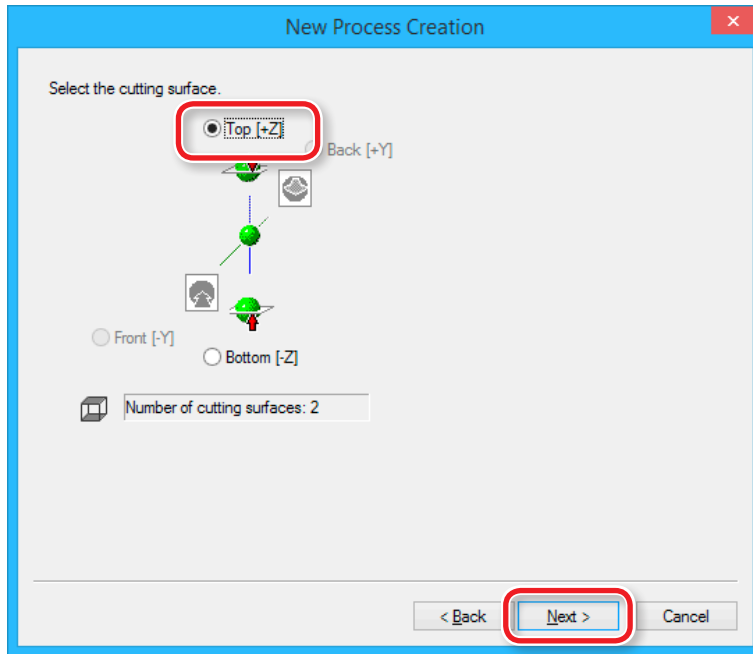

4. Select the cutting tool.

"Perfume.stl": "3 mm Square" → [Next]

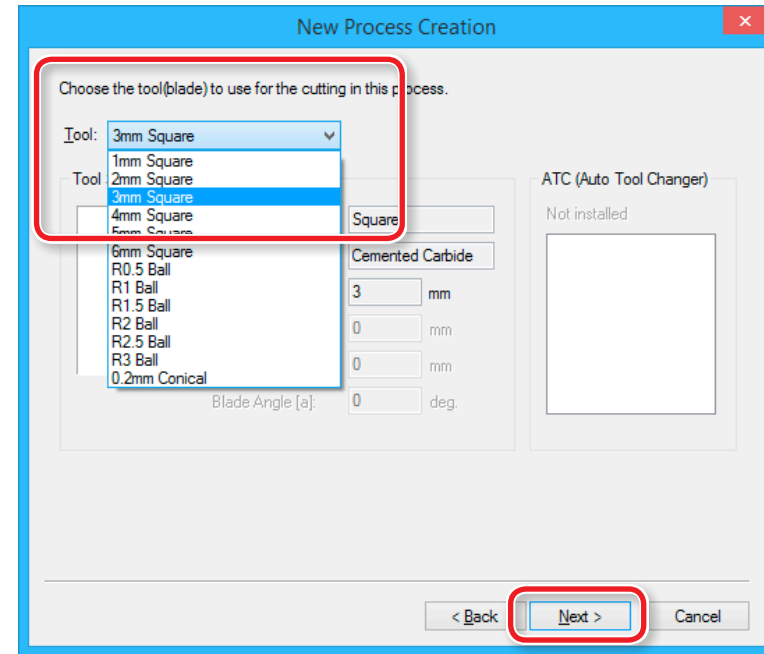

"3 mm Square" is not displayed on the screen

☞ "STEP 2 : Set the Machine Selection" (p. 70)



5. Set the area and depth for surface leveling.

5-1. Set the area of surface leveling.

To level the surface of the scrap board, it is necessary to select [**Specified area**] and specify the area. Enter the X and Y distance from the origin point of the model (bottom left and top right) set in "**STEP 3 : Set the Origin Point of the Model and Orientation**" (p. 71). Set the cutting range so that the entire top surface of the scrap board is horizontal.

5-2. Set the depth of surface leveling.

* Enter a depth that will eliminate the slope of the scrap board.

In most cases, a depth of around 1 mm should suffice. If the slope is too large, measure it with slide calipers, and enter a depth that will make the cutting surface parallel.

☞ User's Manual "**Set Z0 after surface leveling**"

5-3. Click [**Next**].

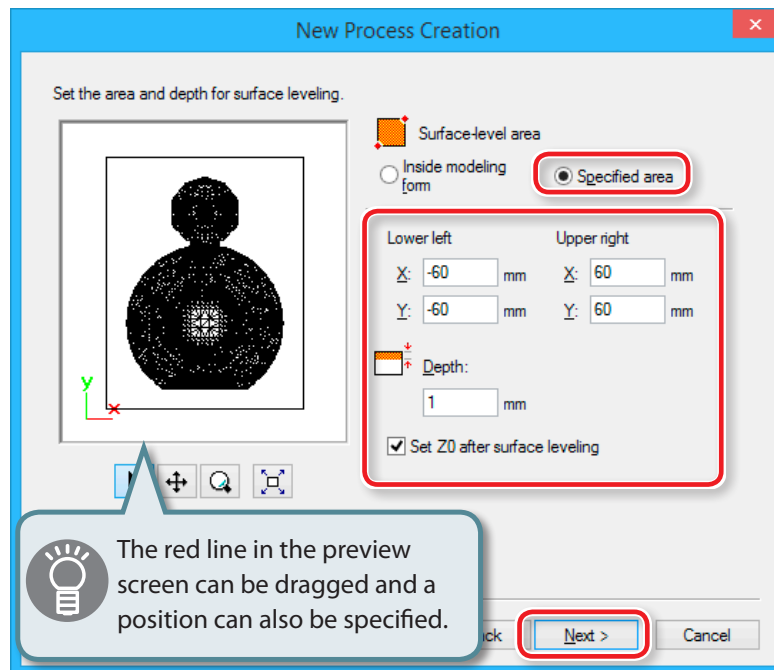

"Perfume.stl" settings (Scrap board:120 (H) x 120 (W) x 10 (D) mm)

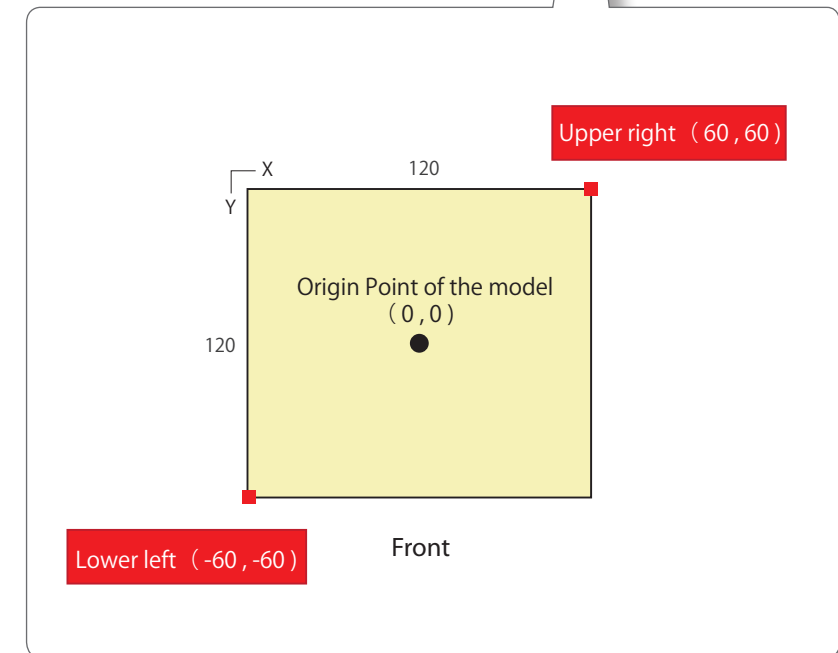
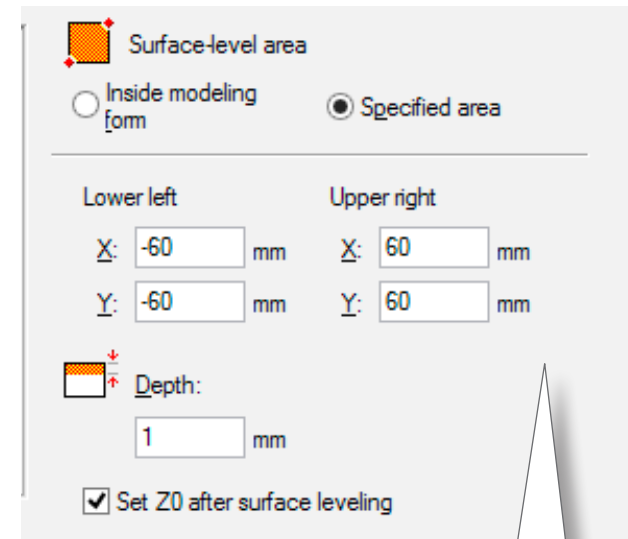



6. Set the tool path.

In the surface leveling process, select the **[Scan Lines]**, then click **"Next."** In **"Perfume.stl"**, cutting results will not change significantly whether **[X]** or **[Y]** is selected.

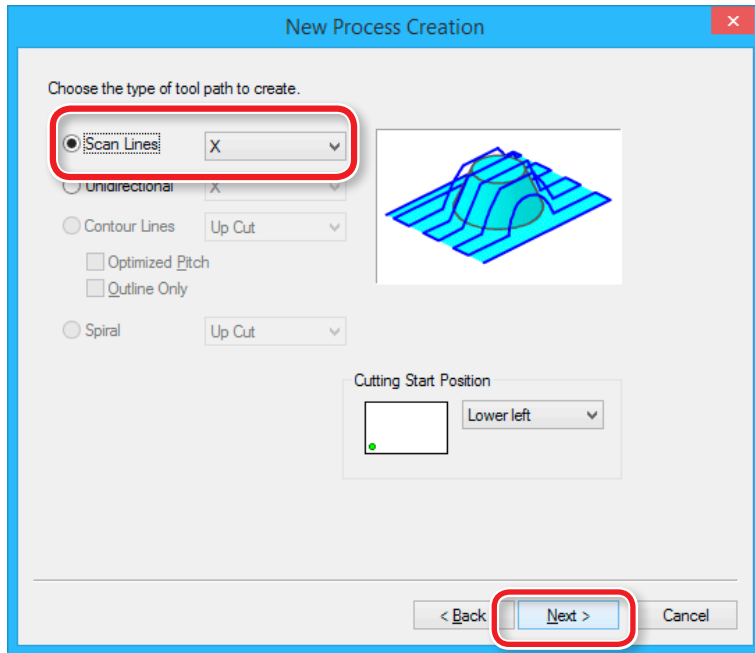

Tool Path

This is the path that is drawn when the cutting tool cuts into the material. Depending on the CAM software used, there are many tool paths for each application.

MODELA Player4 has the following tool paths.

Name	Preview	Feature	Appropriate cutting method
Scan Lines		This creates a tool path parallel to the specified axis. (Parallel with X axis) The path is created in such a way that the outbound movement and return movement lie along the axis.	Surface leveling / Finishing
Uni-directional		This creates a tool path parallel to the specified axis. (Parallel with Y axis) The path is created in such a way that either only the outbound movement or only the return movement lie along the axis.	Surface leveling / Finishing
Contour Lines		This creates a tool path that lies along the contour lines when you're cutting the model into rings on the XY plane.	Roughing / Finishing
Spiral		This creates a spiral tool path.	Finishing



7. Set the cutting parameters.

"Perfume.stl" : No change → [Next]



The appropriate conditions are displayed as the initial values from the selected cutting tool settings and material settings. We recommend using the settings as they are (recommended values) except in situations where you want to make a particular adjustment.

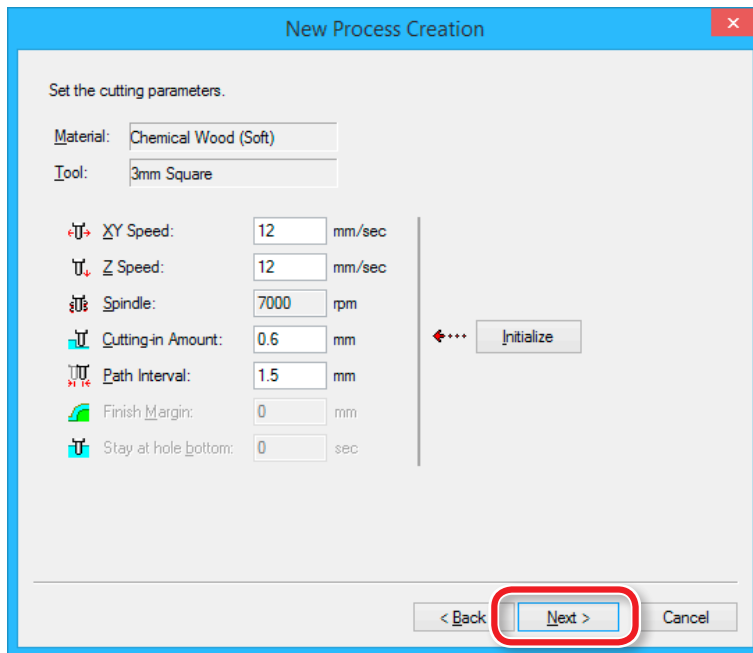

If the scrap board is made from something harder than the material

* In MODELA Player 4, multiple materials cannot be set up simultaneously.

Try the following method depending on the hardness of a board.

- Set the **"Cutting-in Amount"** cutting parameter to a small value
- Replace the cutting tool
- Create a file just for surface leveling of the scrap board

8. Enter a name for this process and create the tool path.

"Perfume.stl" : "Scrap board surfacing" [Right Now] → [Finish]

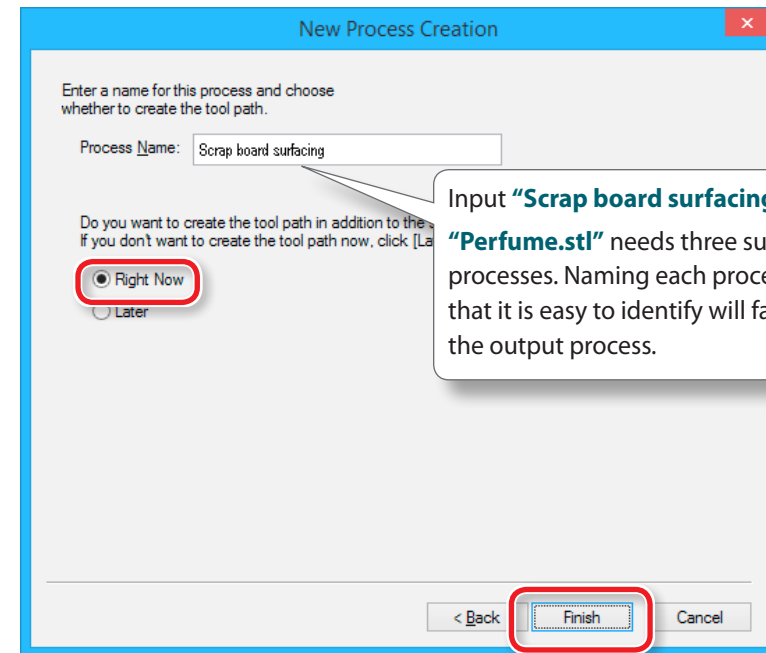



The tool path is created. And the process which is created is displayed.

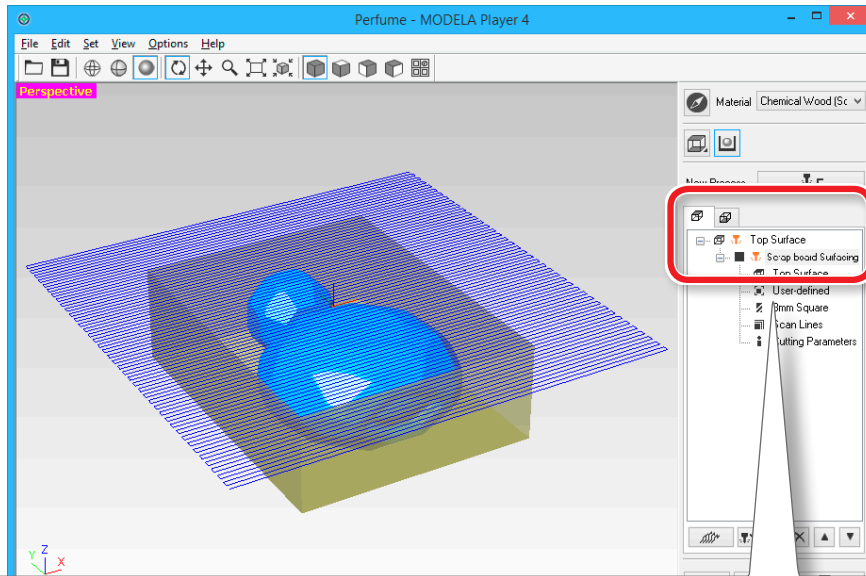

MEMO

A double click of each setting item of a process display a setting screen. The settings can also be changed after the process is created.

STEP 8 : Confirm the Cutting Preview

You can view in 3D and simulate the tool path and cutting tool movement that were set in MODELA Player 4 using the included Virtual MODELA application software. You can also check the estimated cutting time.

☞ Download "<http://startup.rolanddg.com>"

Procedure

1. Click  [Cutting Preview].

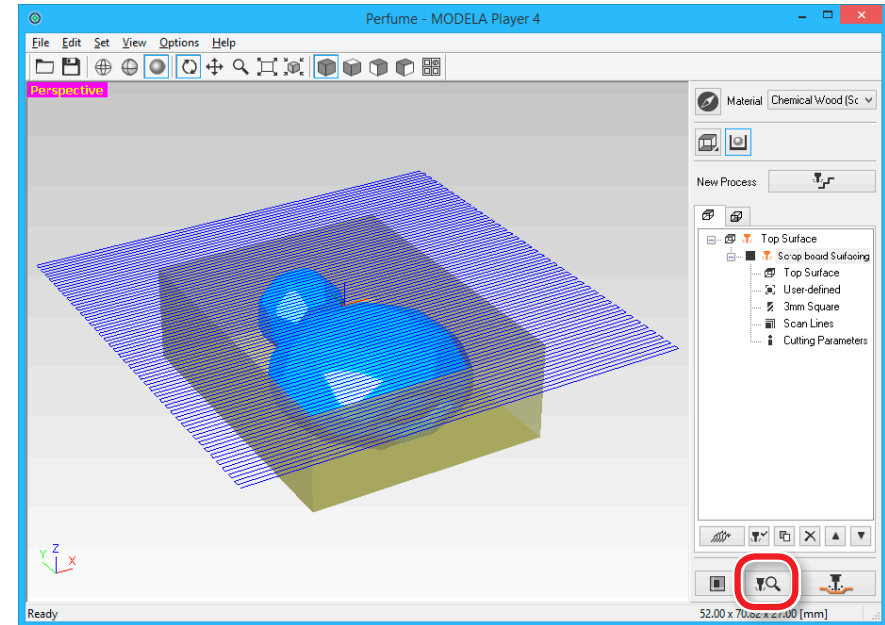



2. When the following screen is displayed, click [OK].

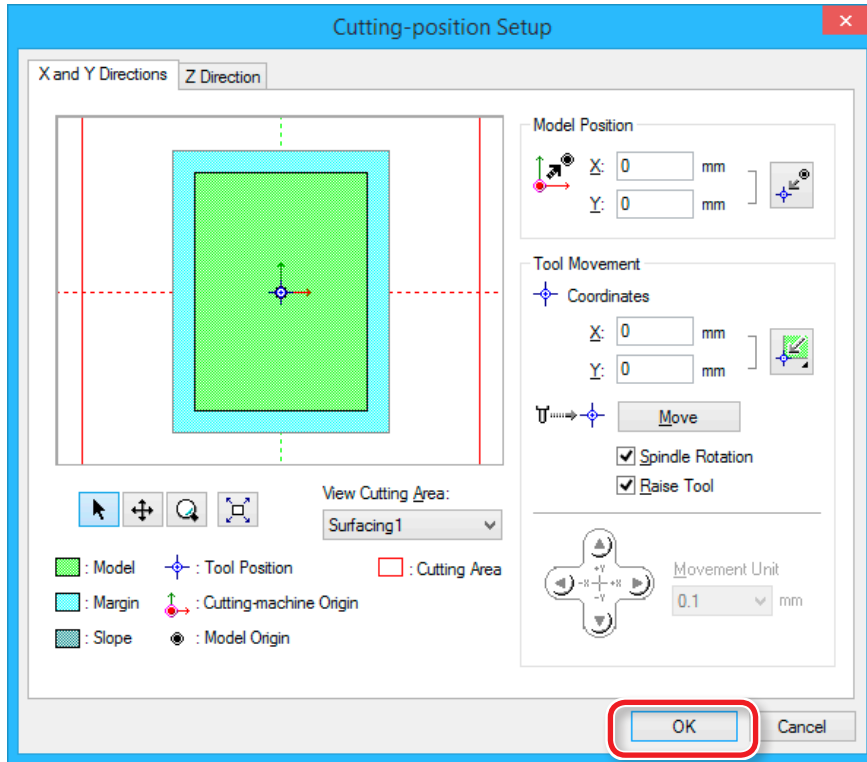

Virtual MODELA starts.

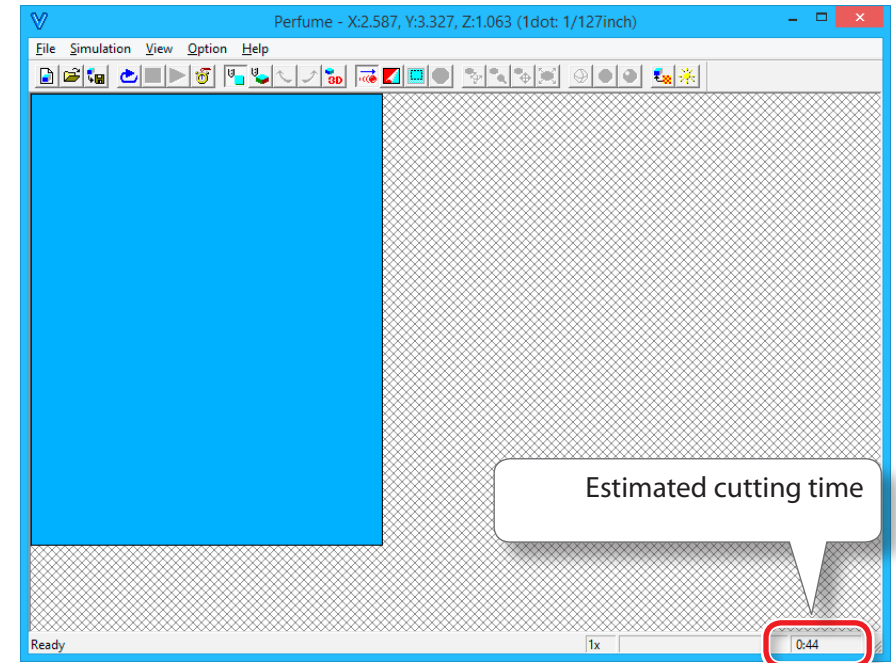

MEMO

For details on the operation methods, please refer to the HELP.
The HELP can be displayed with [HELP] - [Contents] on the menu.

STEP 9 : Set the Surface leveling Process of the Material

Surface leveling of the Material

Leveling eliminates unevenness in the surface of a material to make it parallel with the cutting plane along which the cutting tool moves. For double-sided cutting, each of the top and bottom surfaces must be leveled. The leveling cutting depth should be set to a value calculated using the following formula so that the material is not smaller than the model size:

$$(\text{Material thickness}) - (\text{Model height}) > \text{Leveling cutting depth (top surface + bottom surface)}$$

“Perfume.stl”

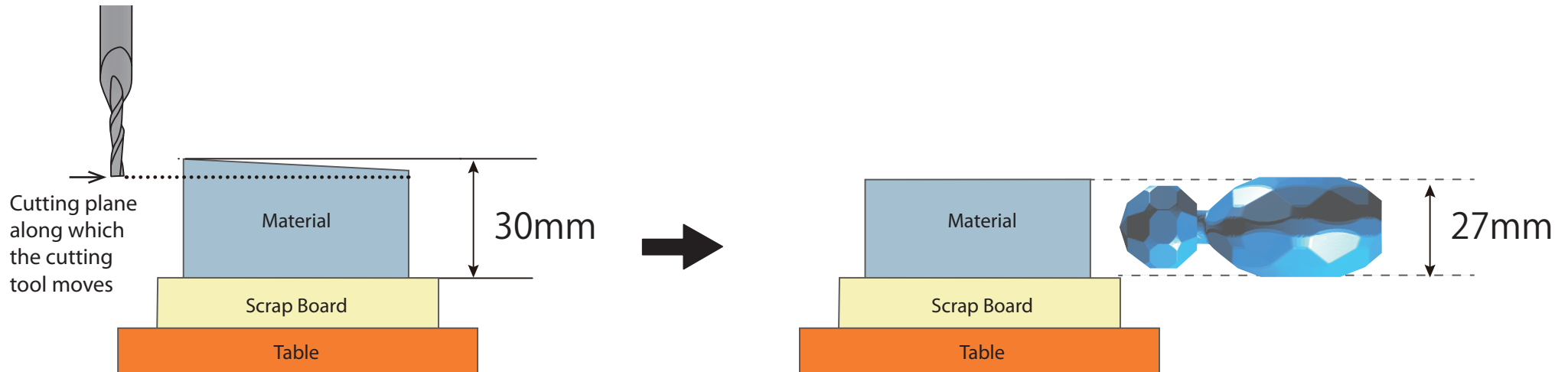



Procedure

1. Create the surface leveling process of material.

Select the top surface, then click  [New Process].

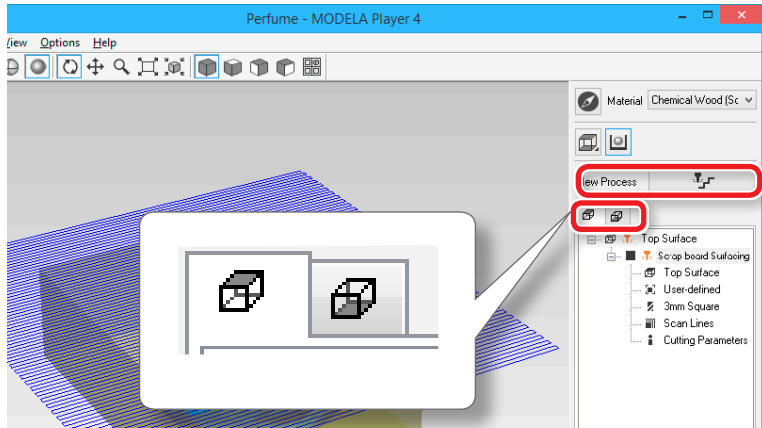

3. Set the cutting surface.

Check that the surface selected in procedure 1 is selected, and click [Next].

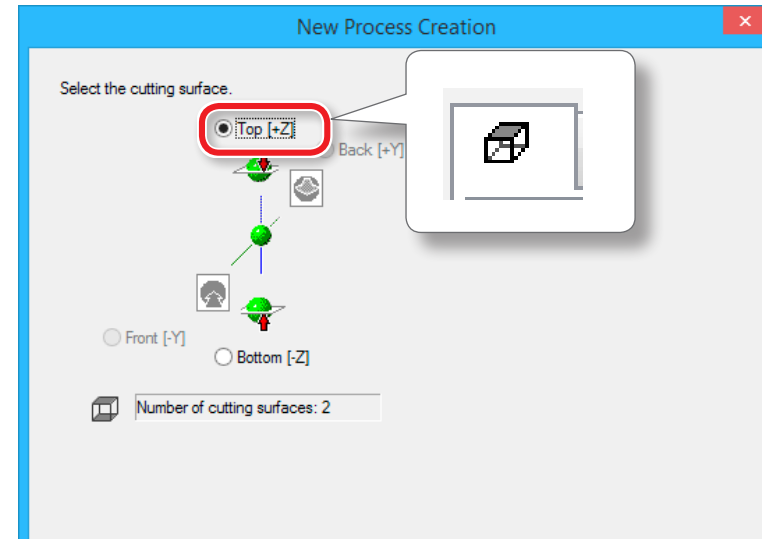

2. Set the type of process.

Select [Surfacing], then click [Next].

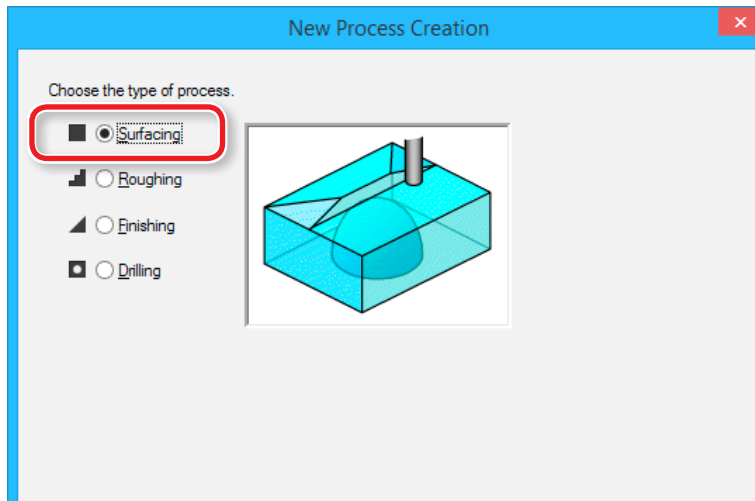

4. Select the cutting tool.

"Perfume.stl": "3 mm Square" → [Next]

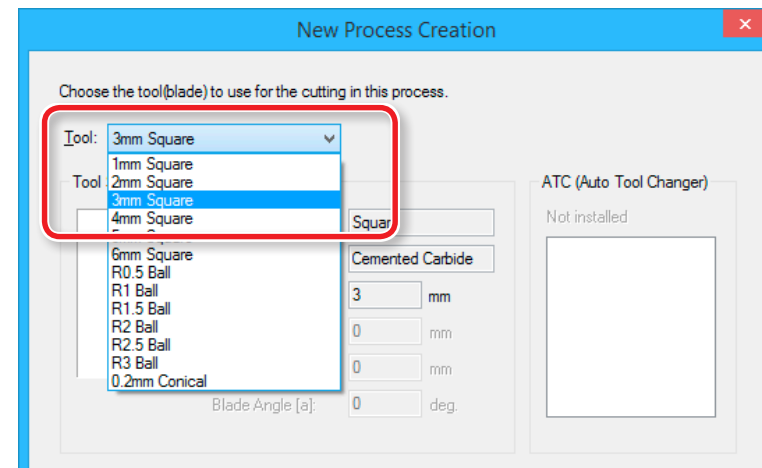



5. Set the area and depth for surface leveling.

5-1. Select the area of surface leveling.

[Inside modeling form] : Automatic input

[Specified area] : Manual input

5-2. If you selected **[Specified area]**, manually enter the cutting area.

Enter the X and Y distance from the origin point of the model (bottom left and top right) set in **"STEP 3 : Set the Origin Point of the Model and Orientation"** (p. 71)

5-3. Set the depth of surface leveling.

The leveling cutting depth should be set to a value calculated using the following formula so that the material is not smaller than the model size:

$$(\text{Material thickness}) - (\text{Model height}) > \text{Leveling cutting depth (top surface + bottom surface)}$$

5-4. Click **[Next]**.

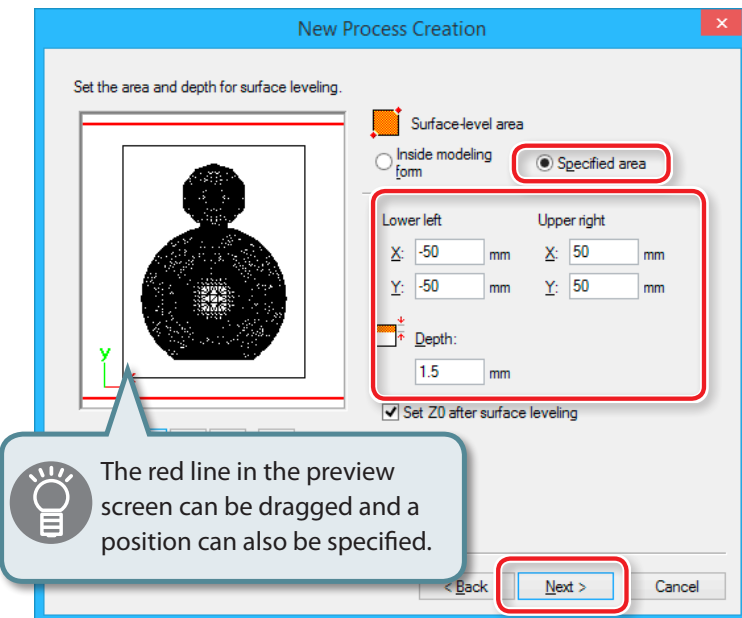

"Perfume.stl" setting (Material :100 (H) x 100 (W) x 30 (D) mm)

Inside modeling form
 Specified area

Lower left Upper right
 X: -50 mm X: 50 mm
 Y: -50 mm Y: 50 mm

 Depth:
 1.5 mm

Set Z0 after surface leveling

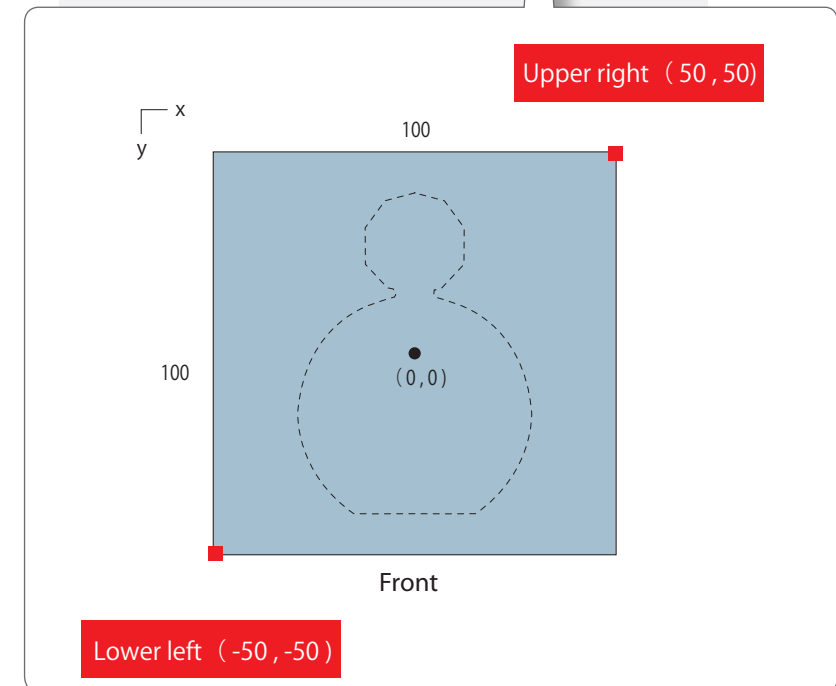



6. Set the tool path.

☞ “Tool Path” (p. 78)

“Perfume.stl” : [Scan Lines] → [Next]

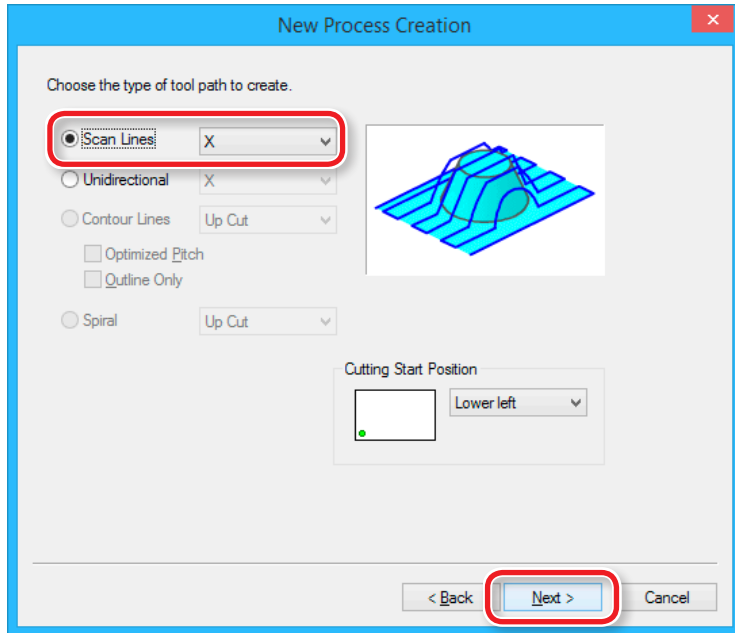

7. Set the cutting parameters.

“Perfume.stl” : No change → [Next]



The appropriate conditions are displayed as the initial values from the selected cutting tool settings and material settings. We recommend using the settings as they are (recommended values) except in situations where you want to make a particular adjustment.

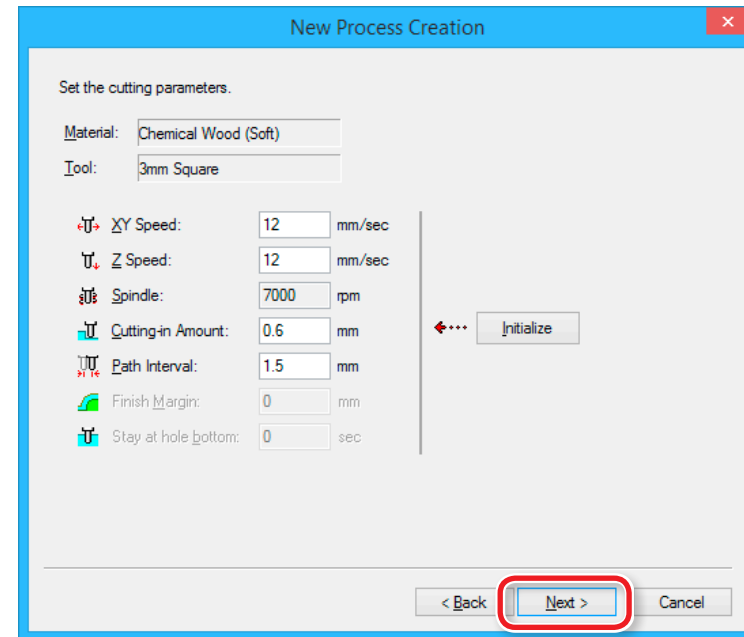



8. Enter a name for this process and create the tool path.

“Perfume.stl”: “Material surfacing” [Right Now] → [Finish]

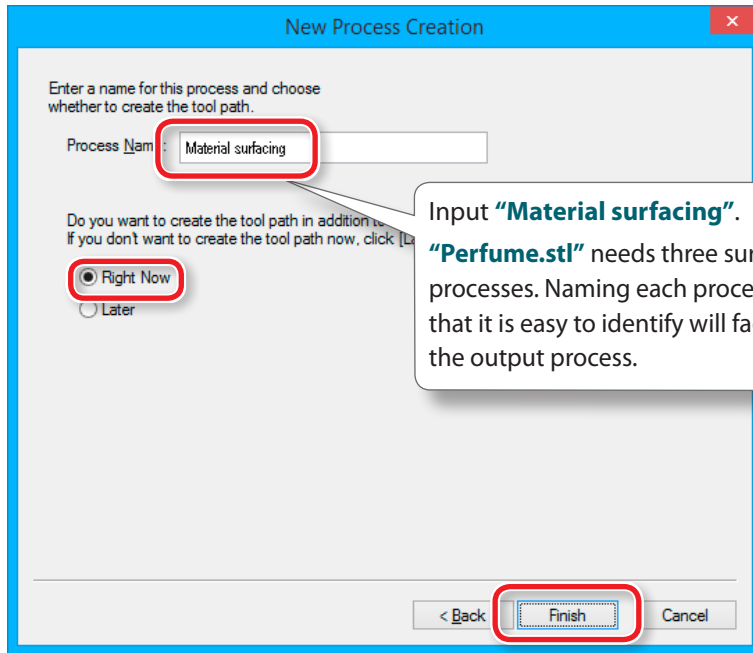

The tool path is created. And the process which is created is displayed.

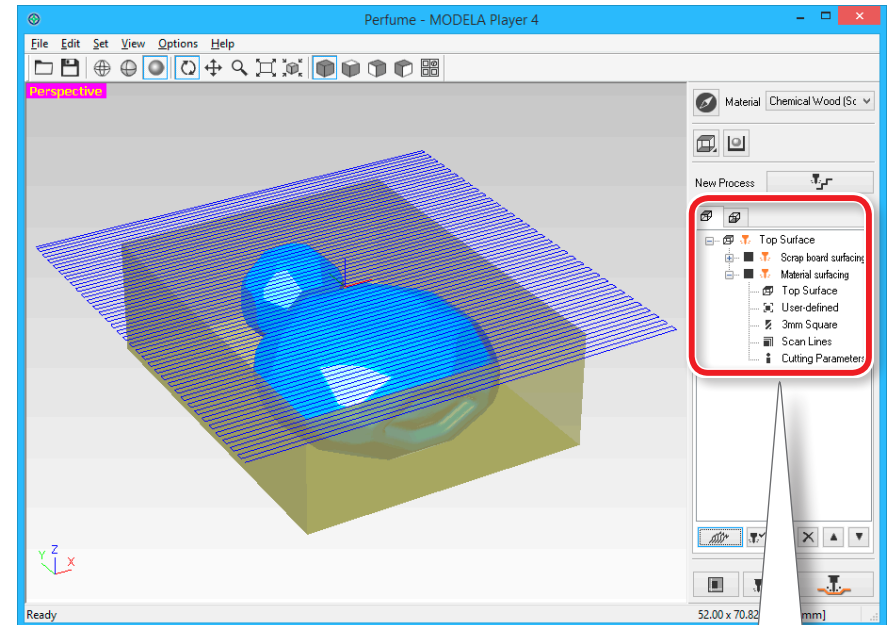

9. Check the cutting preview by Virtual MODELA.

☞ “STEP 8 : Confirm the Cutting Preview” (p. 81)

STEP 10 : Set the Roughing Process

Roughing

This task cuts a rough outline and leaves the detailed portions. This is an important process for reducing cutting time and increasing the efficiency of the finishing process.

Procedure

1. Create the roughing process.

Select the top surface, click  [New Process].

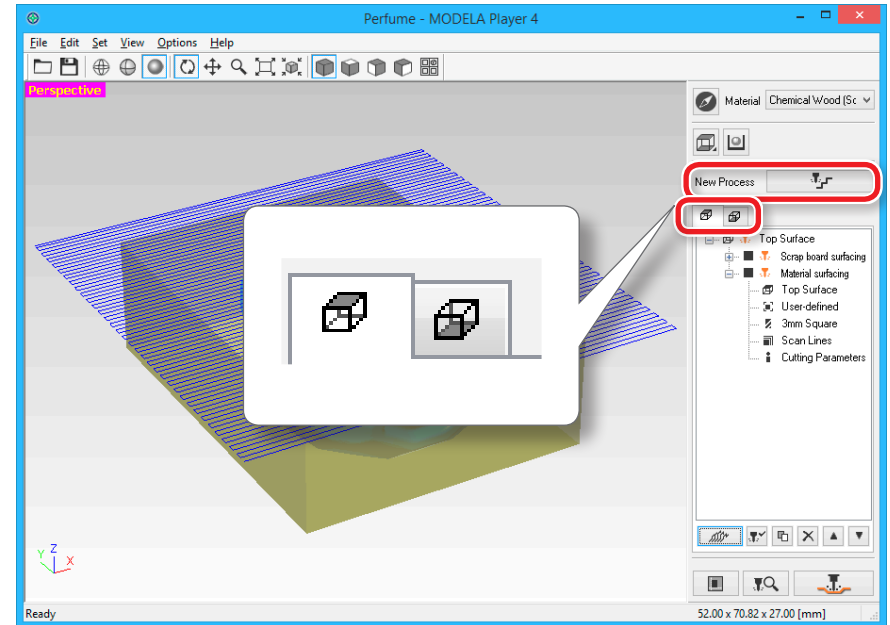



2. Set the type of process.

Select **[Roughing]** and click **[Next]**.

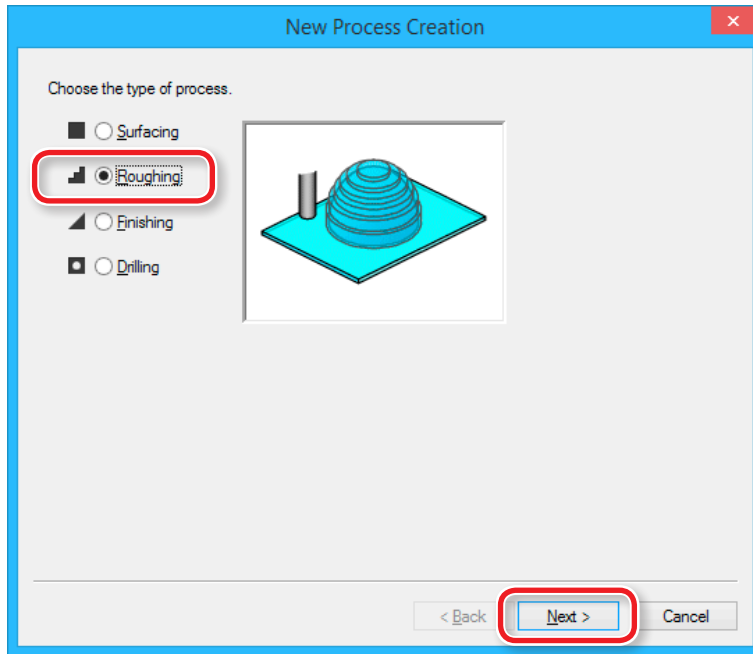

3. Set the cutting surface.

Check that the surface selected in procedure 1 is selected, and click **[Next]**.

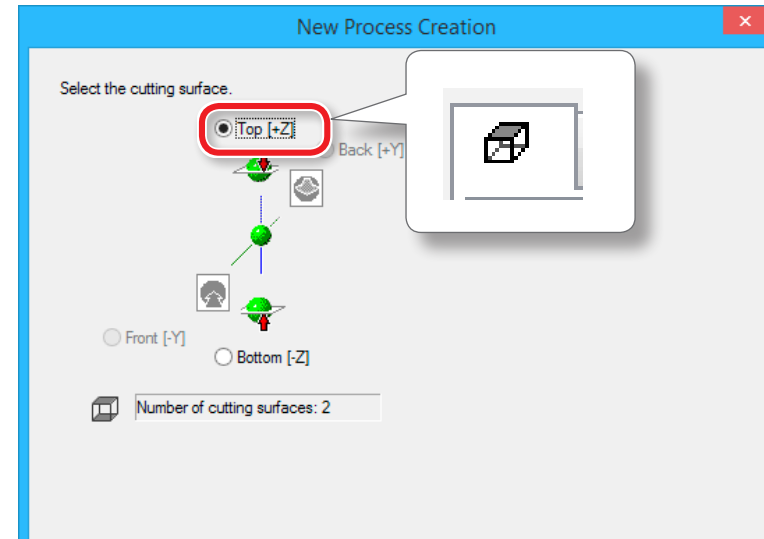

4. Select the cutting tool.

"Perfume.stl" : [3 mm Square] → [Next]

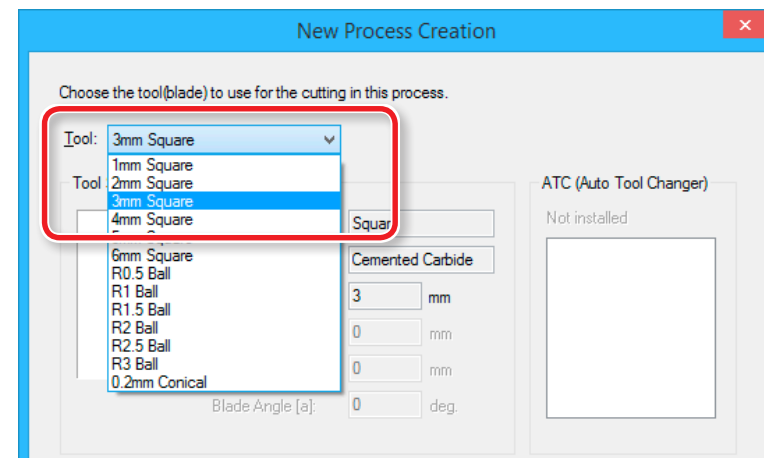



5. Set the area and depth for roughing.

5-1. Set the area of roughing.

For double-sided cutting, select **[Partial]** : Manual input

5-2. Enter the cutting area.

Enter the X and Y distance from the origin point of the model (bottom left and top right) set in **"STEP 3 : Set the Origin Point of the Model and Orientation"** (p. 71).

5-3. Set the depth for roughing.

The roughing depth varies depending on the model geometry. Make adjustments while looking at the red line in the preview screen.

5-4. Click **[Next]**.

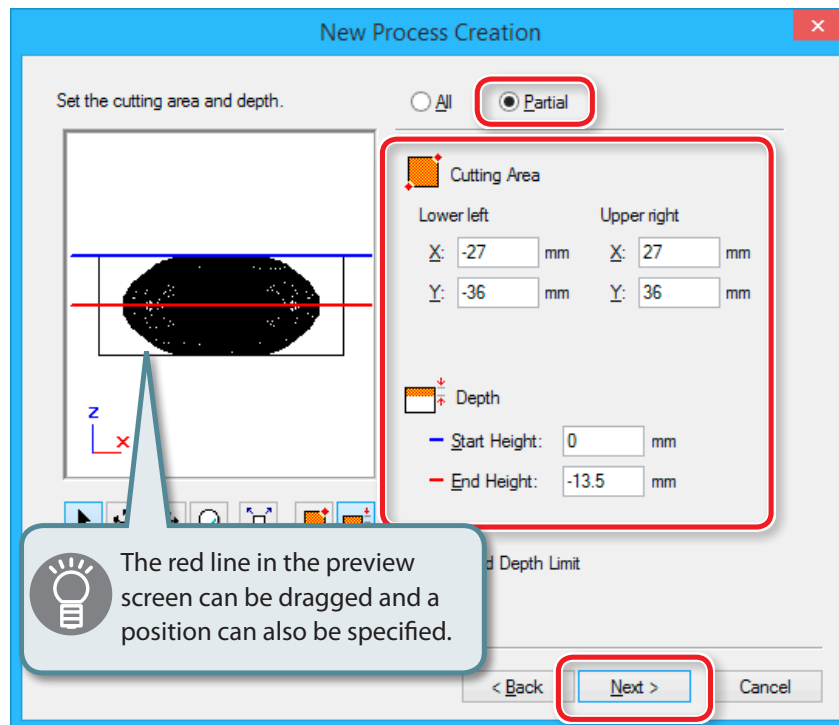

"Perfume.stl" Setting (Data:70 (H) x 52 (W) x 27 (D) mm)

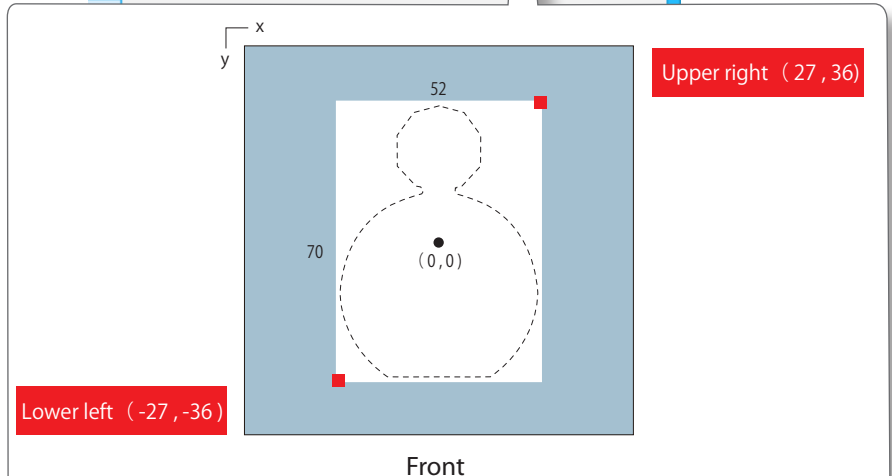
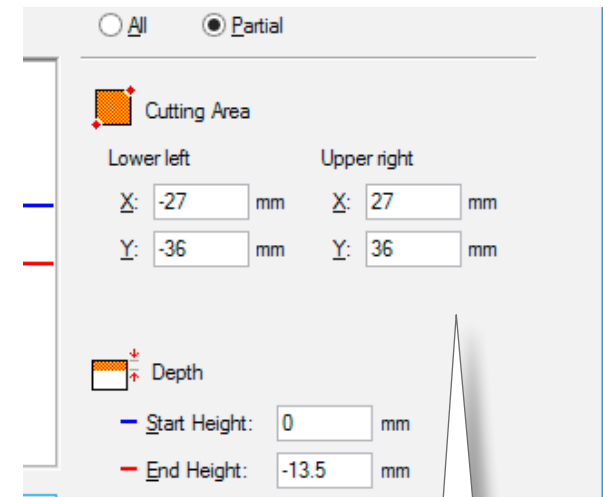

For double-sided cutting, non-cutting areas (i.e., **"support"**) must be left in margin spaces to support the model so that it will not detach during cutting. To create this support, configure the settings so that **"-1 mm"** and **"+1 mm"** are added to the lower-left (X/Y) and upper-right (X/Y) distances, respectively.

☞ **"Supports"** (p. 92)



6. Set the tool path.

☞ “Tool Path” (p. 78)

“Perfume.stl” : [Contour Lines] [Up Cut] → [Next]

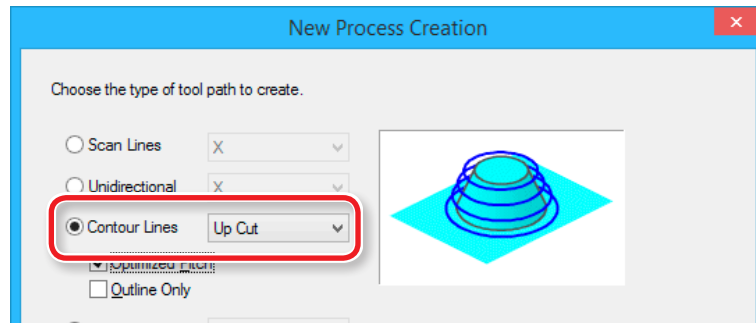

7. Set the cutting parameters.

“Perfume.stl” : No change → [Next]



The appropriate conditions are displayed as the initial values from the selected cutting tool settings and material settings. We recommend using the settings as they are (recommended values) except in situations where you want to make a particular adjustment.

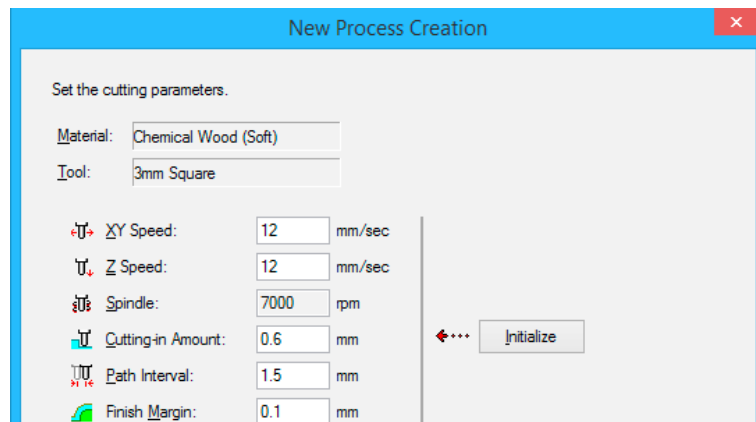

8. Enter a name for this process and create the tool path.

“Perfume.stl”: “Roughing” [Right Now] → [Finish]

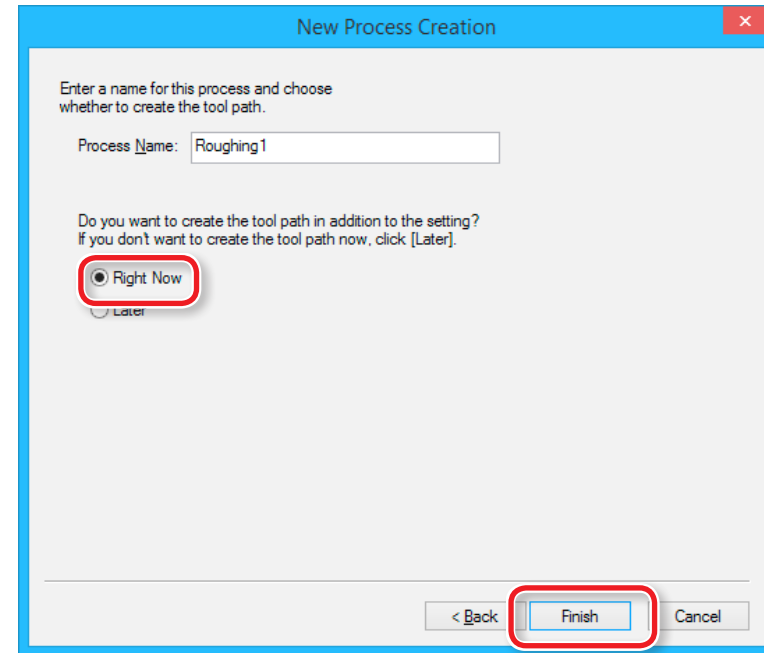

The tool path is created. And the process which is created is displayed.



9. Check the cutting preview by Virtual MODELA.

☞ “STEP 8 : Confirm the Cutting Preview” (p. 81)



When simulation can be checked again, click  (Redo Cutting).

Note : “Perfume.stl”

In this manual, the cutting width is adjusted to create supports. If there are no supports, the cut areas will not be fixed and cutting will not be possible.

When checking data in Virtual MODELA, check that the areas in the red boxes are present.

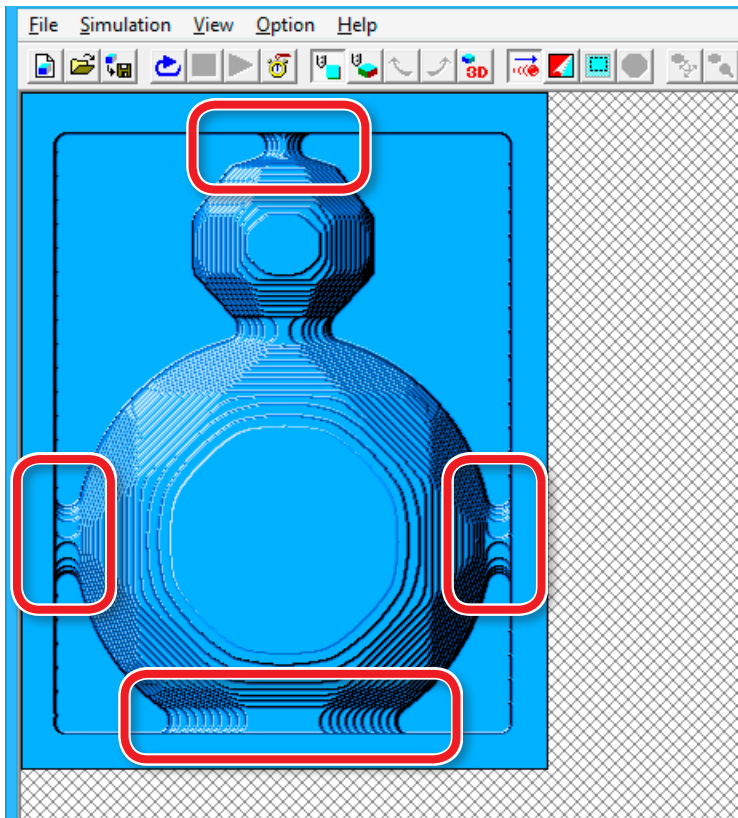

Supports

“**Supports**” are the parts of the frame that support the material and the object being cut. They are often seen in plastic models and similar products.

Supports

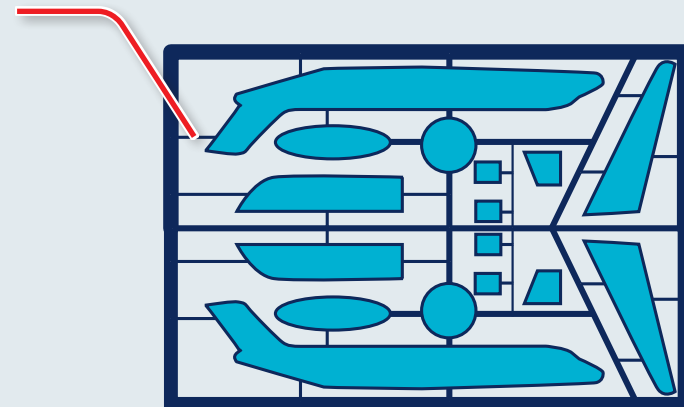

STEP 11 : Set the Finishing Process

Finishing

The finishing process cuts the finely detailed portions according to the shape of the data. A cleaner finish can be obtained by effectively using the types of cutting tools.

Procedure

1. Create the finishing process.

Click  **[New Process]**.

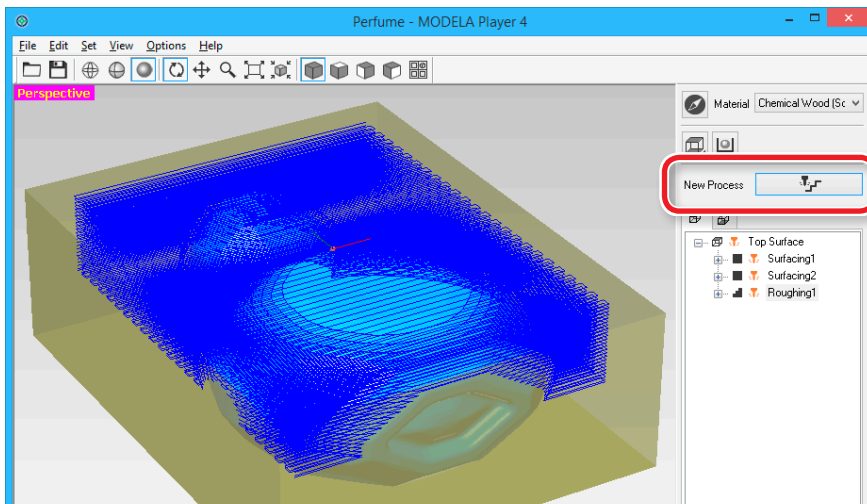

2. Set the type of process.

Select **[Finishing]** and click **[Next]**.

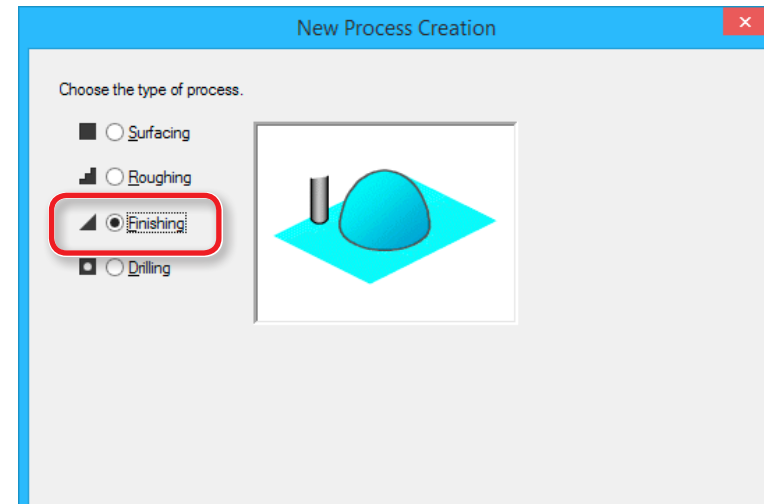



3. Set the cutting surface.

Check that the surface selected in procedure 1 is selected, and click **[Next]**.

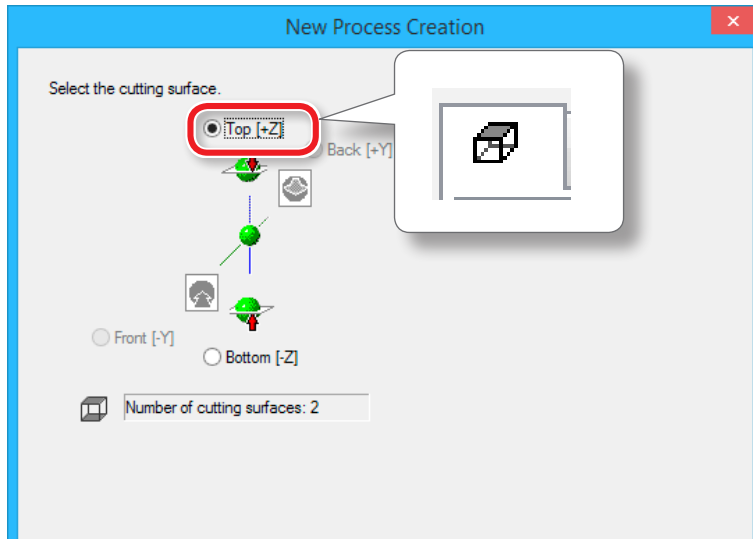

4. Select the cutting tool.

“Perfume.stl”: [3 mm Square] → [Next]

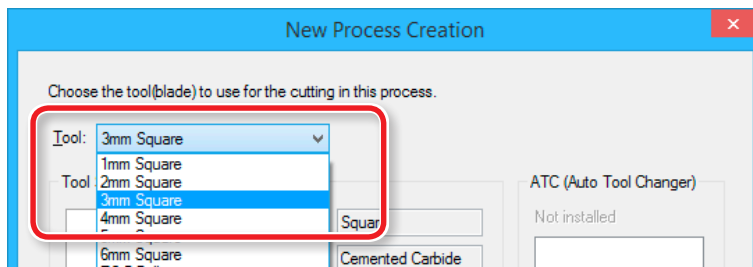

This manual assumes that the standard “3 mm Square” tool is used for “**roughing**” and “**finishing**.” When machining an actual workpiece, select a cutting tool with a shape and diameter suitable for the purpose.

☞ **User’s Manual “Cutting Tools”**

5. Set the area and depth for finishing.

5-1. Select the cutting area.

5-2. Input the cutting area.

5-3. Set the area for finishing.

5-4. Click **[Next]**.

“Perfume.stl”: Enter the same values as for roughing.

☞ “5. Set the area and depth for roughing.” (p. 90)

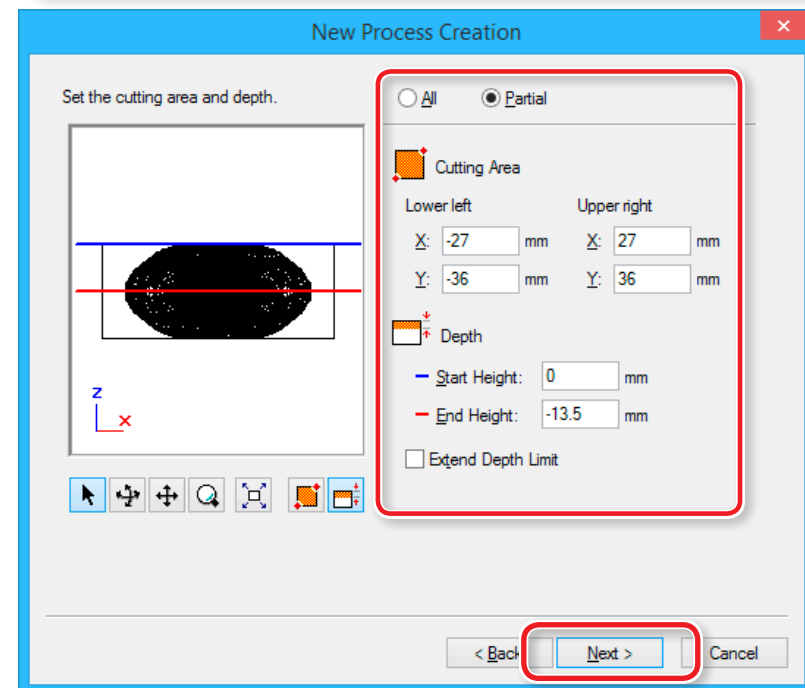



6. Set the tool path.

☞ “Tool Path” (p. 78)

“Perfume.stl” : [Contour][Up Cut][Optimized Pitch] → [Next]

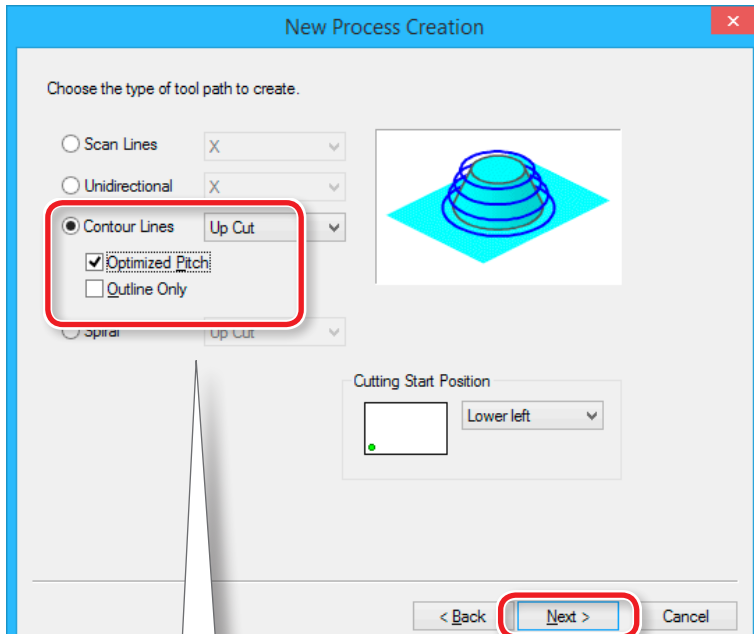

This Function enabled only in the finishing process.

[Optimized Pitch]

This reduces the cutting-in amount for areas that have a gentle slope, thereby reducing uncut areas. The cutting-in amount is automatically adjusted within a range that does not exceed the specified parameters.

[Outline Only]

This cuts only the outline of the model. It creates only contour-line tool paths, without creating-scan line tool paths.

7. Set the cutting parameters.

“Perfume.stl” : No change → [Next]



The appropriate conditions are displayed as the initial values from the selected cutting tool settings and material settings. We recommend using the settings as they are (recommended values) except in situations where you want to make a particular adjustment.

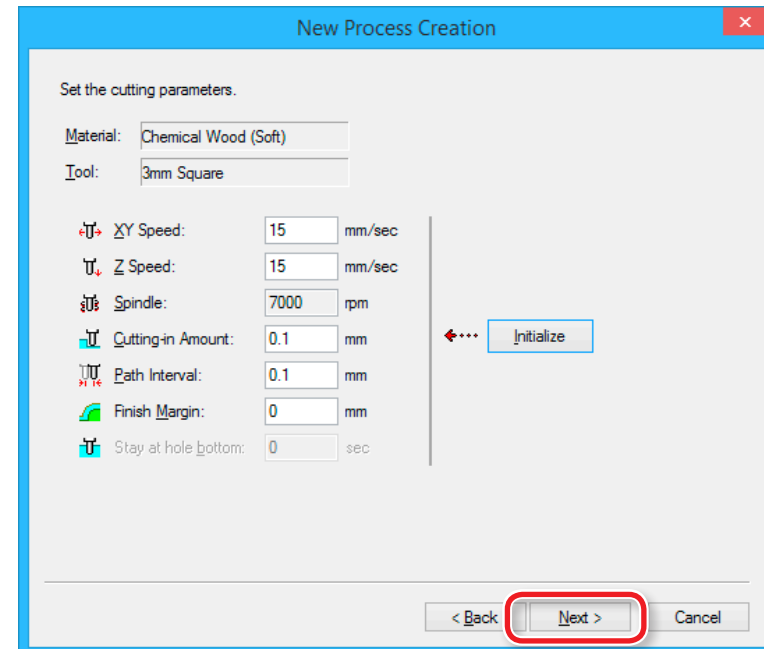



8. Enter a name for this process and create the tool path.

“Perfume.stl”: [Right Now] → [Finish]

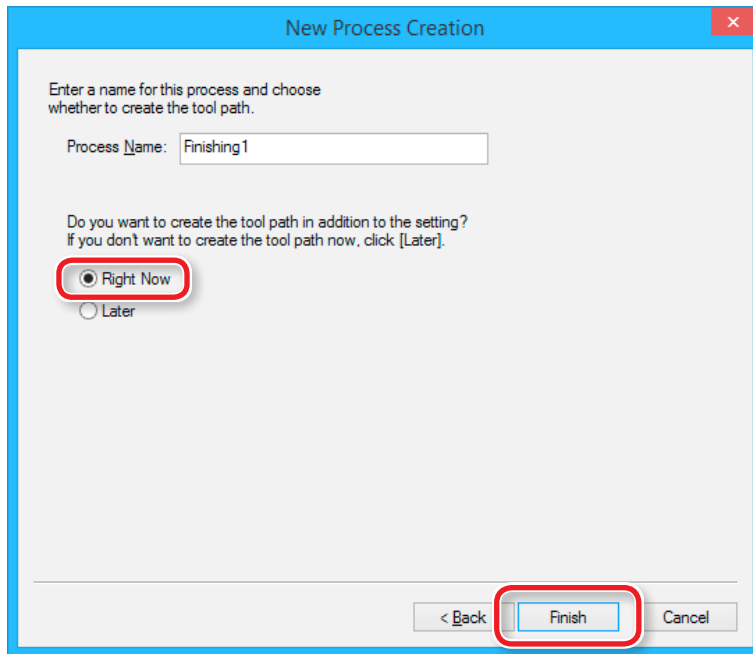

The tool path is created. And the process which is created is displayed.

9. Check the cutting preview by Virtual MODELA.

☞ “STEP 8 : Confirm the Cutting Preview” (p. 81)

STEP 12 : Set the Drilling Process

Drilling

Several reversal methods can be used to cut both sides accurately in the same position. The procedure described in this section assumes that positioning pins are used to reverse the cutting material. The procedure involves drilling holes for inserting positioning pins.

Reversal process using positioning pins

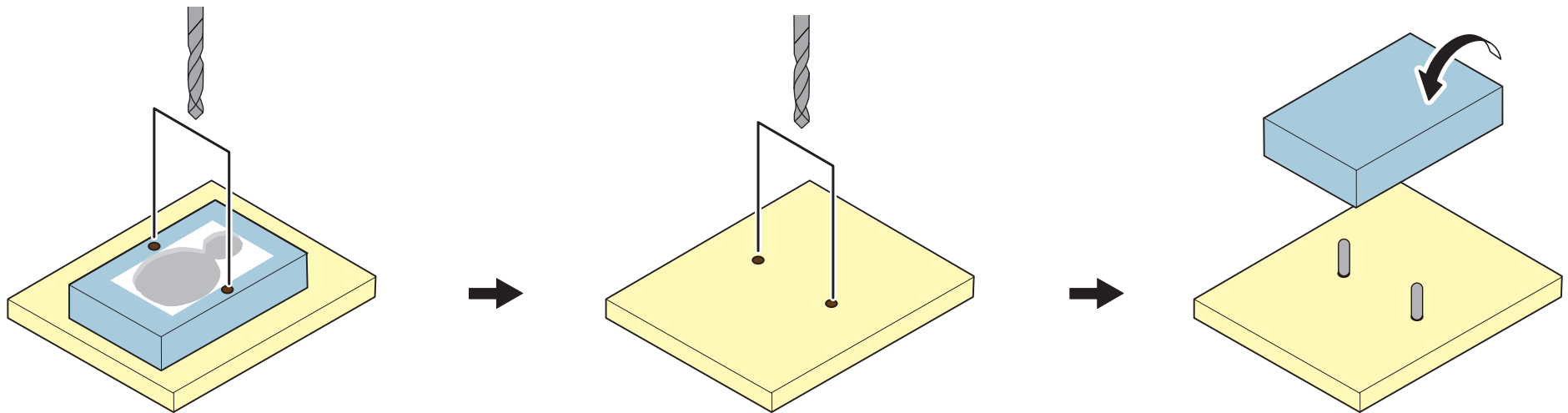



Procedure

1. Create the roughing process.

Select the top surface, click  [New Process].

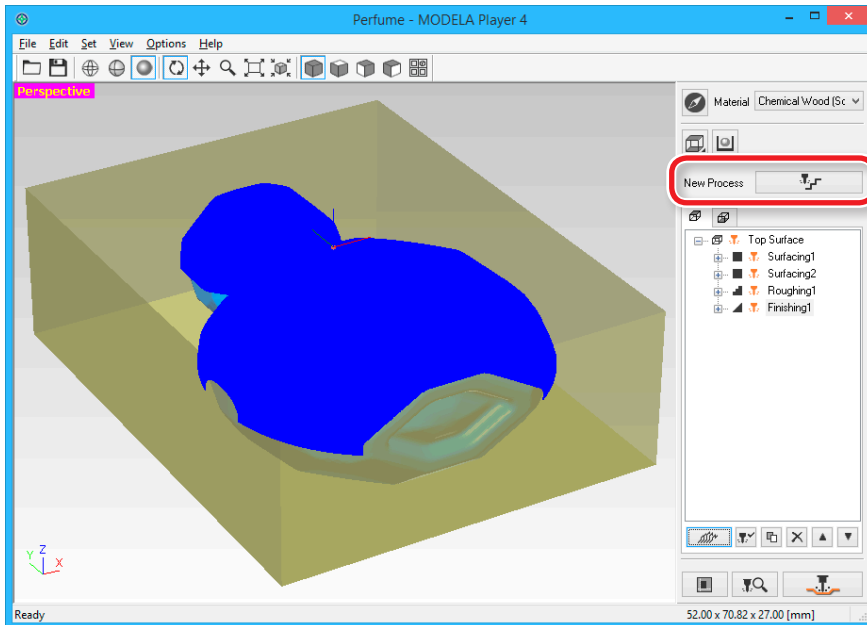

2. Set the type of process.

Select [**Drilling**] and click [**Next**].

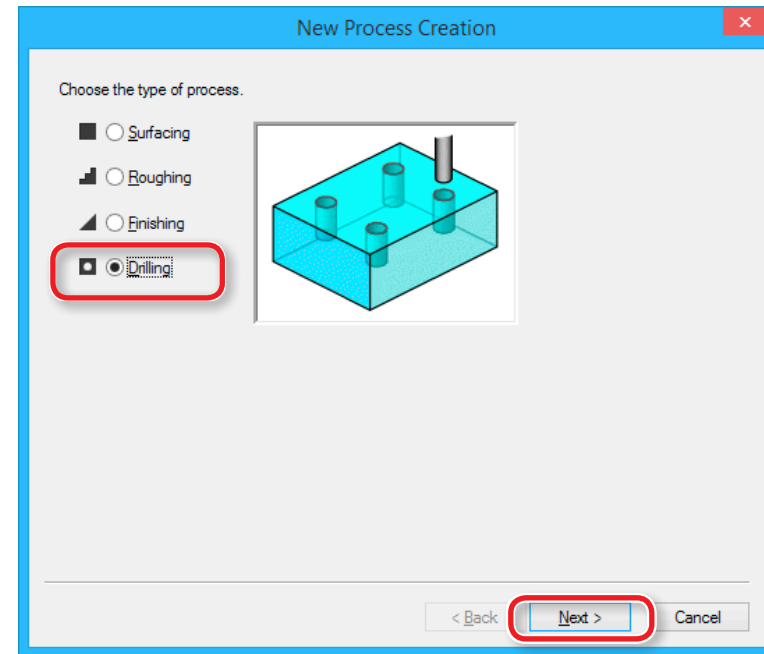



3. Set the cutting surface.

"Perfume.stl" : [Top [+Z]] → [Next]

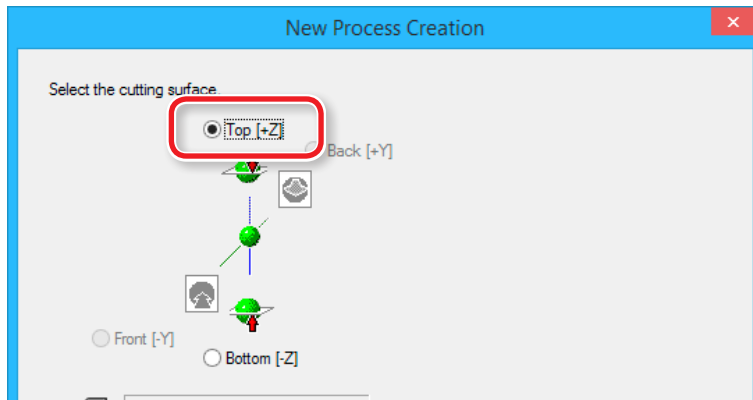

4. Select the cutting tool.

"Perfume.stl" : [3 mm Drill] → [Next]

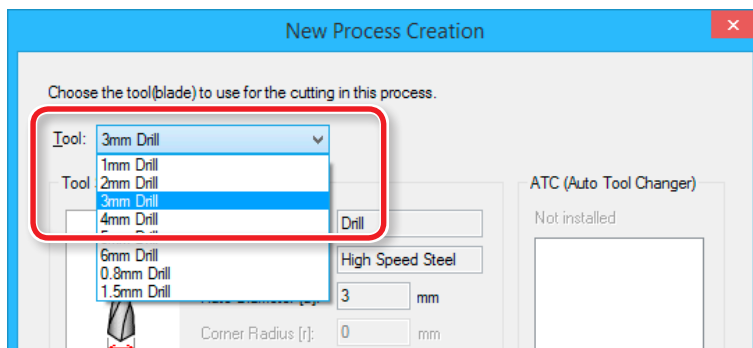

Make a selection that matches the drill to be used.

With MODELA Player 4, [Drill] is the only cutting tool that can be selected for a drilling process. However, you can perform a drilling process with [3 mm Drill] selected if you use the standard cutting tool that comes with the machine.

☞ User's Manual "Cutting Tools"

5. Create the hole location data.

5-1. Click [New].

The icon  which indicate a hole location is displayed on a preview.

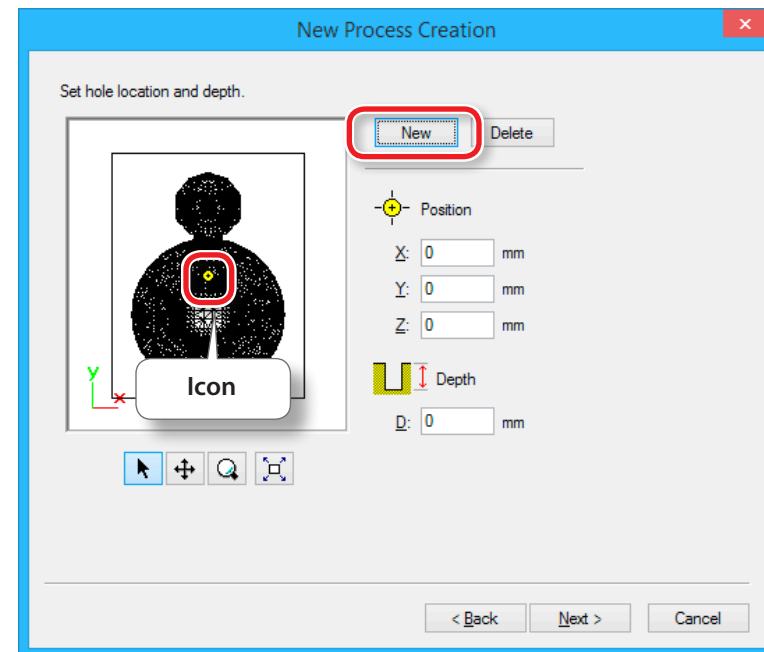



5-2. Input the hole location and depth.

"Perfume.stl": [X : 40] [Y : 0] [Z : 0] [D : 5]

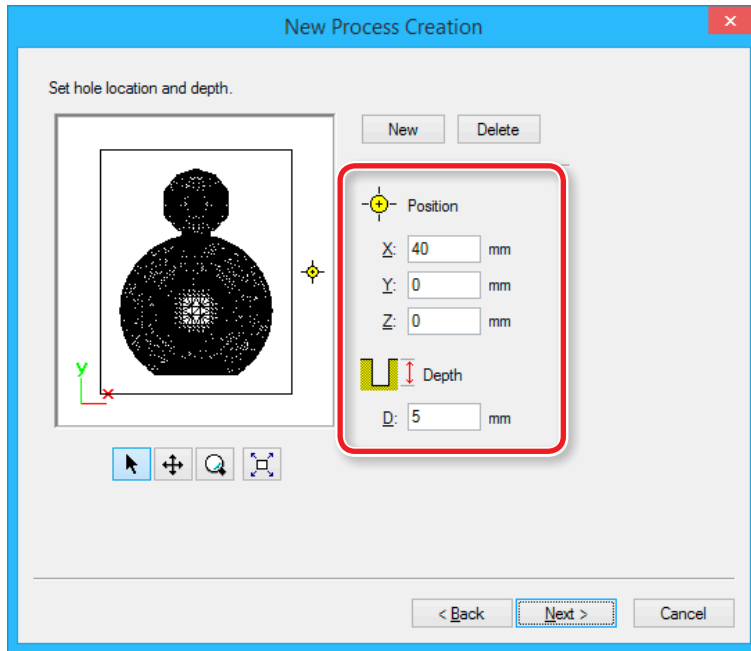

The depth of hole drilling

Set "**Depth**" to around half the length (5 mm) of the positioning pin used when reversing the object.

Points to note when determining hole position

Material is fixed firmly.

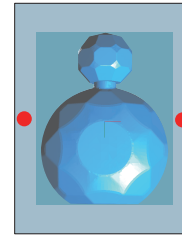

OK

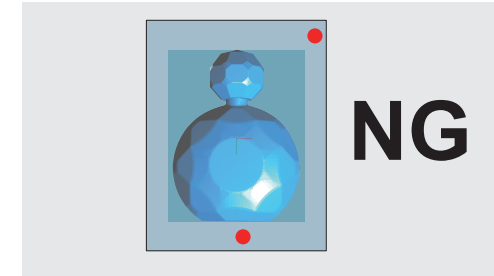

NG

Do not set outside the width of material.

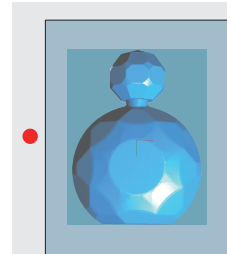

NG

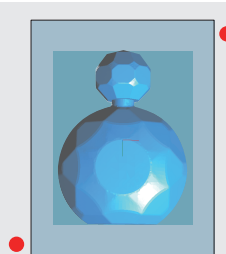

NG

Do not set within cutting area.

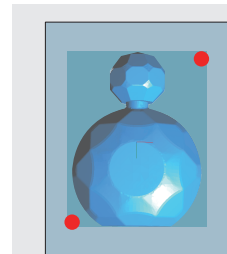

NG

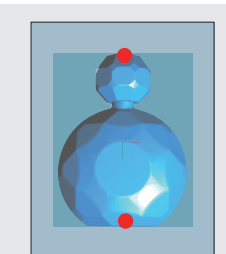

NG



6. Create the second data.

Click **"New"**, and enter the second hole position and depth.

"Perfume.stl" : [X : -40][Y : 0][Z : 0][D : 5] → [Next]

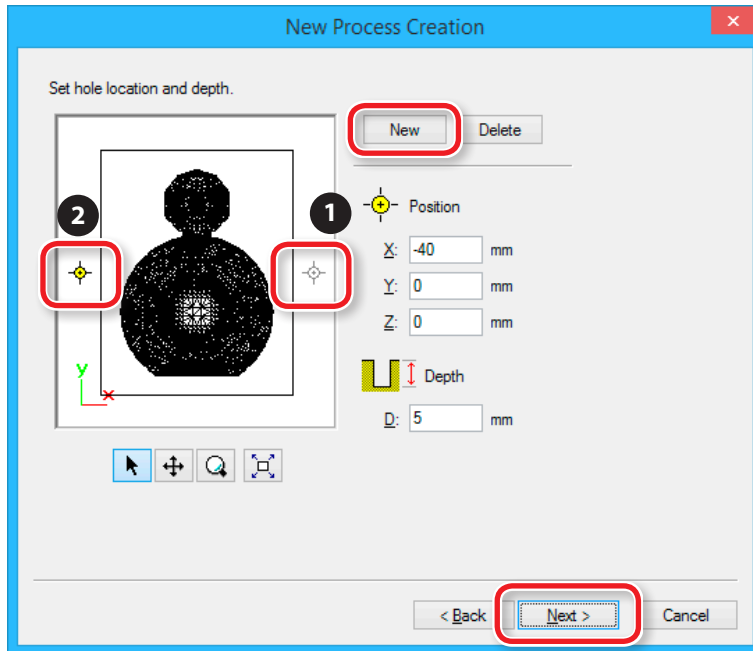

A position can also be specified by dragging the icon .

7. Set the cutting parameters.

"Perfume.stl" : No change → [Next]



The appropriate conditions are displayed as the initial values from the selected cutting tool settings and material settings. We recommend using the settings as they are (recommended values) except in situations where you want to make a particular adjustment.

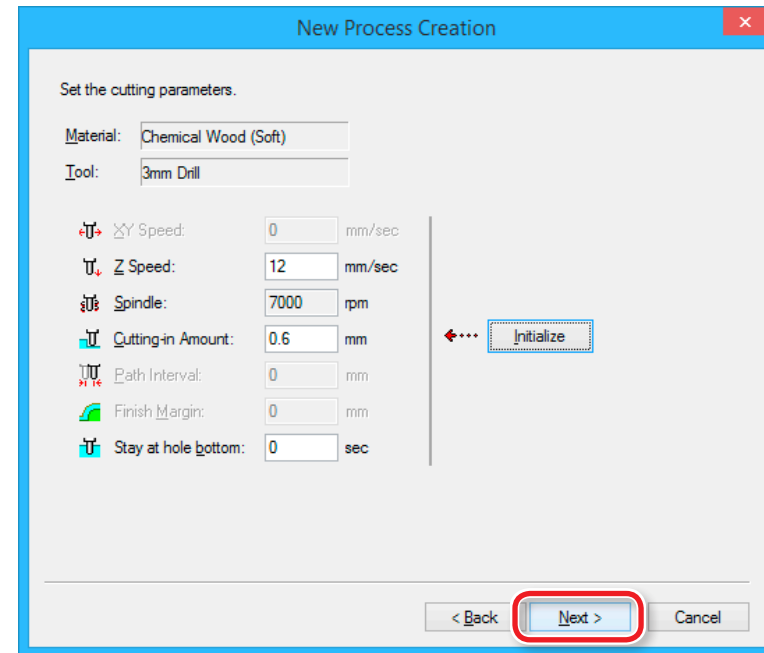



8. Enter a name for this process and create the tool path.

“Perfume.stl”: [Right Now] → [Finish]

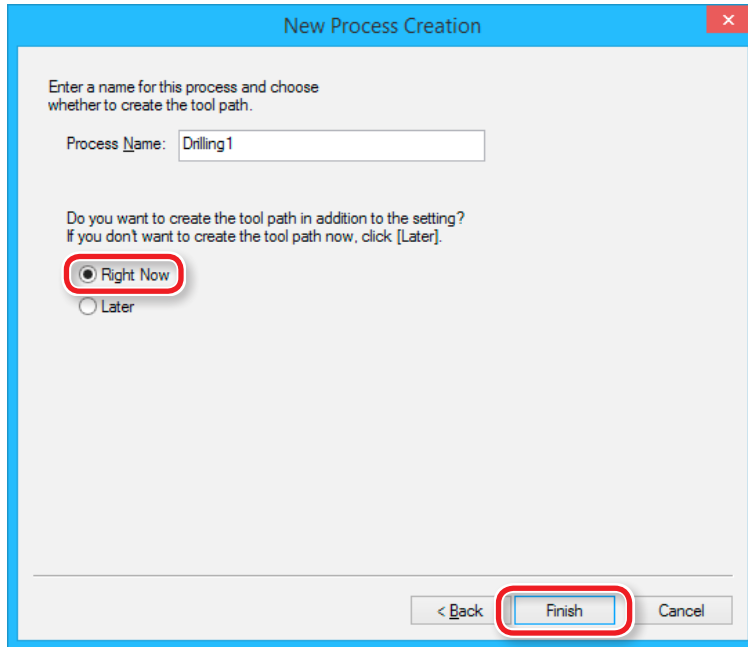

The tool path is created. And the process which is created is displayed.

9. Check the cutting preview by Virtual MODELA.

☞ “STEP 8 : Confirm the Cutting Preview” (p. 81)

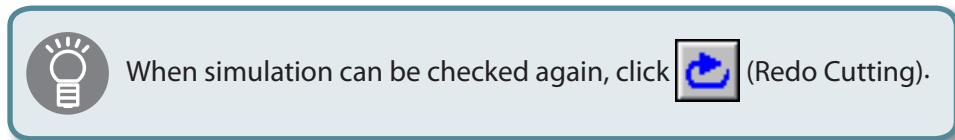

STEP 13 : Set the Bottom Surface Process

Create the data for the bottom surface in the same way as for the top surface.

Procedure

1. Click the tab of bottom surface.
The displayed figure is reversed.

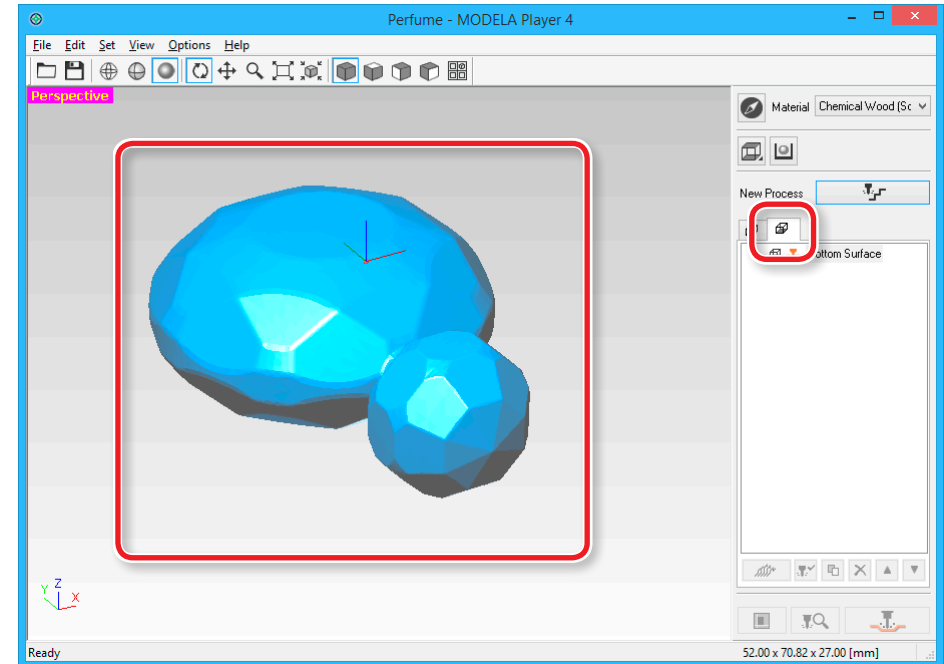



2. Select the bottom surface, perform the same work as top surface.

* In the bottom surface, surface leveling of material and drilling process are unnecessary.

☞ “STEP 9 : Set the Surface leveling Process of the Material” (p. 83)

☞ “STEP 10 : Set the Roughing Process” (p. 88)

☞ “STEP 11 : Set the Finishing Process” (p. 93)

3. A setup is completed, go to “Cutting (Double Sided)” (p. 105).

“Perfume.stl”: Enter the same values as for the top surface. The figure at lower right shows how the model look will look like when you check the finished state using Virtual MODEL A after completing the settings:

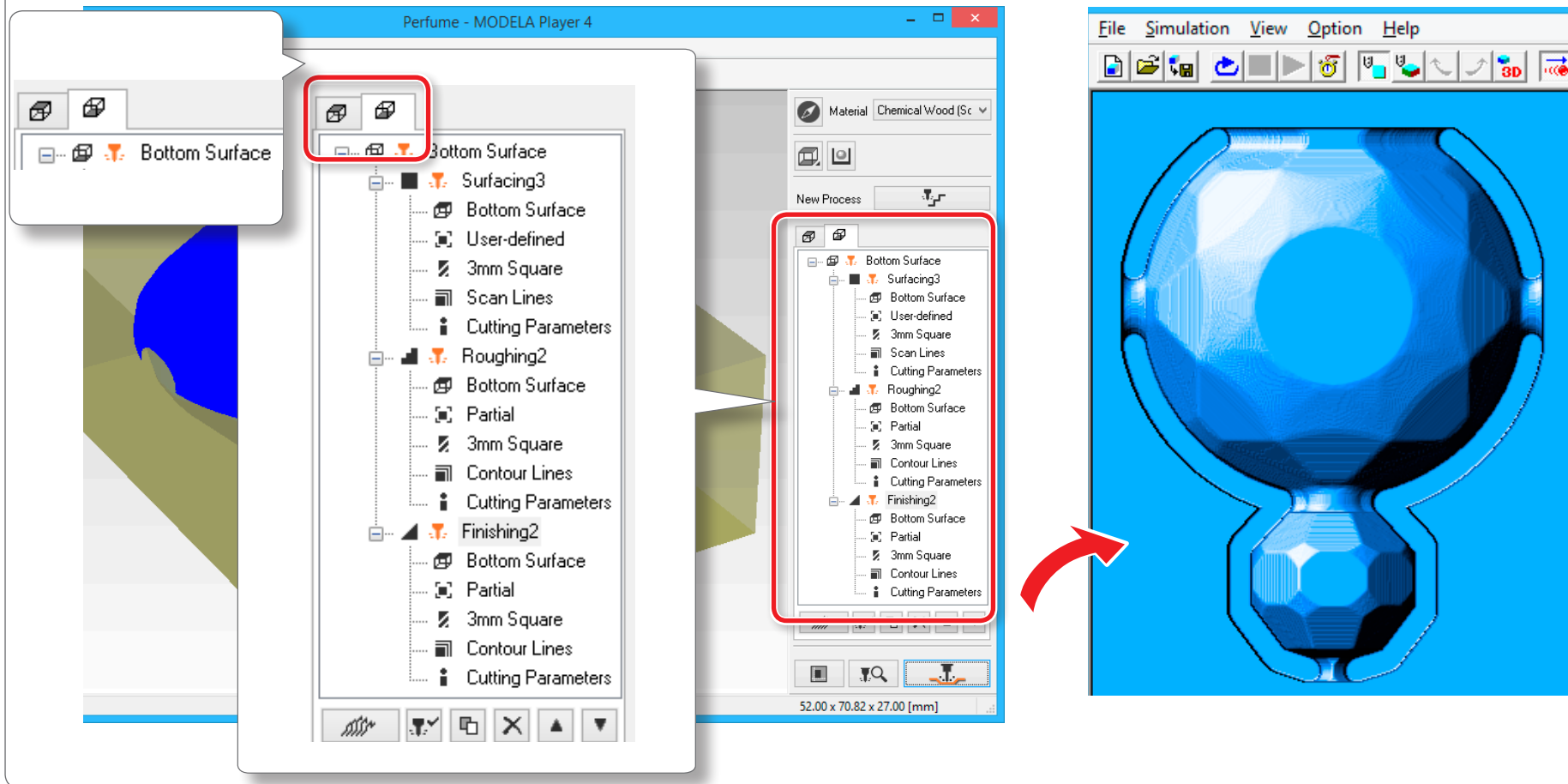

Cutting (Double Sided)

Preparing

"STEP 1 : Attach the Material to the Scrap Board" (p. 106)
"STEP 2 : Set the Origin Point" (p. 108)

Top surface
cutting

"STEP 3 : Perform the Surface Leveling of the Scrap Board" (p. 112)
"STEP 4 : Perform the Surface Leveling of the Material" (p. 115)
"STEP 5 : Perform the Roughing" (p. 116)
"STEP 6 : Perform the Finishing" (p. 118)
"STEP 7 : Perform the Drilling in the Material" (p. 120)
"STEP 8 : Perform the Drilling in the Scrap Board" (p. 122)
"STEP 9 : Reverse the Material" (p. 123)

Bottom surface
cutting

"STEP 10 : Cut the Bottom Surface" (p. 126)
"STEP 11 : Remove the Cut Material" (p. 126)

"STEP 12 : Turning the Power Off" (p. 127)



STEP 1 : Attach the Material to the Scrap Board

Scrap Board

A scrap board is a board that is placed under the material when cutting it so that the table is not cut.

It is used as a temporary, subsidiary material when cutting out the material or when drilling holes for positioning when cutting.

☞ User's Manual "**Cutting Material / Scrap Boards**"

Procedure

- 1. Mark the location that will be the origin point of the scrap board.**

Draw the diagonal line and mark the center point of the scrap board.

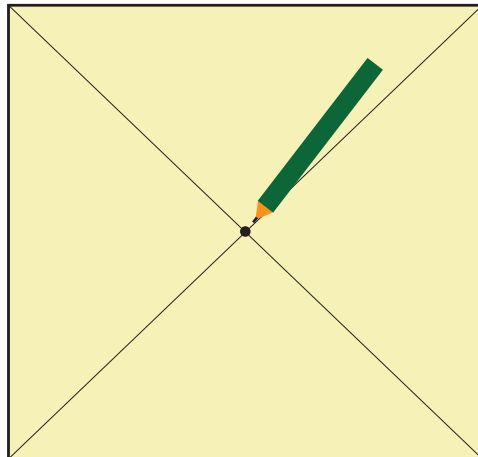

- 2. Stick double-stick tape on the scrap board.**

An adhesion side is made large so that the scrap board may not separate during cutting.

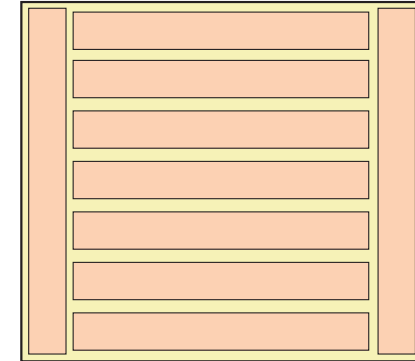
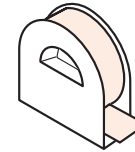



3. Click [View] of VPanel.



4. Pull down the front guard and loosen the screws at the positions shown in the figure.

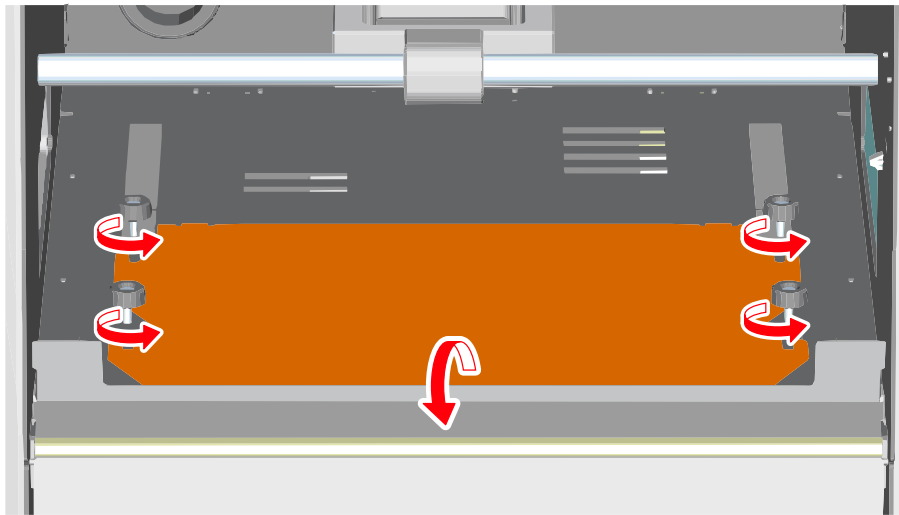

5. Affix the scrap board to the removed table, and slot the table under the screws.

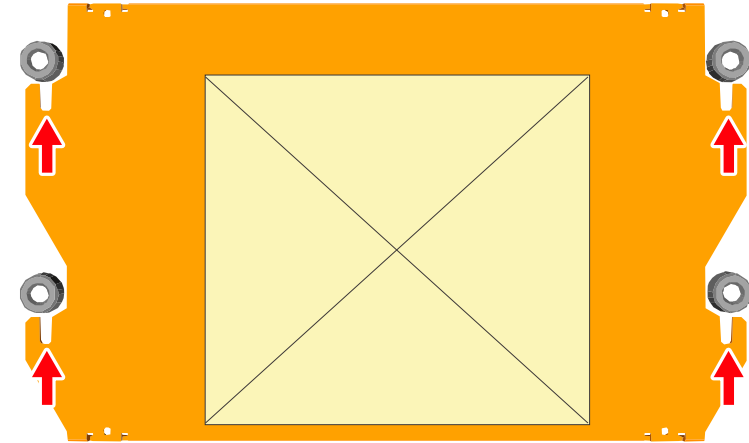

Front

6. Tighten the screws firmly and return the front guard to the original position.

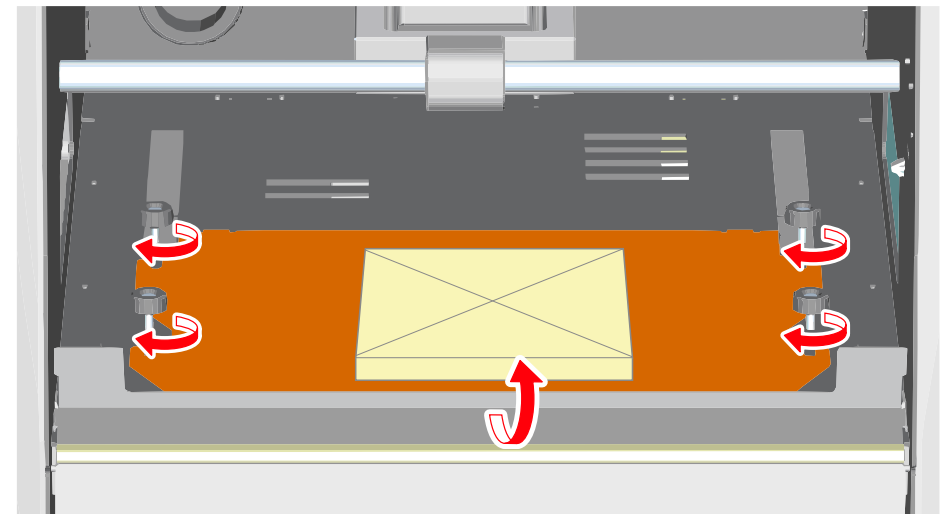

STEP 2 : Set the Origin Point

About Origin Point

Before you start cutting, you must set the origin point. When you cut with this machine, you need to set the X, Y, and Z origins.

The X and Y origins are determined by the cutting data and the location of the material. (“X” and “Y” cannot be set individually.) You normally align the Z origin with the surface of the material. Take the size of the material and the length of the cutting tool into consideration when you set the origins.

In addition, the locations that you should specify for the origins vary depending on the application software that you are using. Set up depending on the specification of the application software that you are using.

☞ User’s Manual “Origin point of the Model / Origin point”

1. Prepare to set the origin point

1. Select [Machine Coordinate System] on the VPanel.

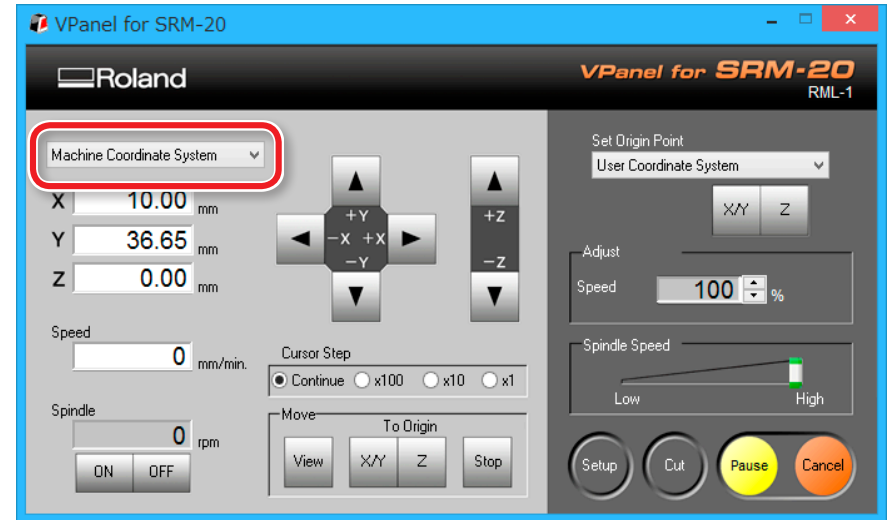

2. Click [X/Y][Z] of [Origin] in [Move].





3. Check that XYZ is "0.00 mm."

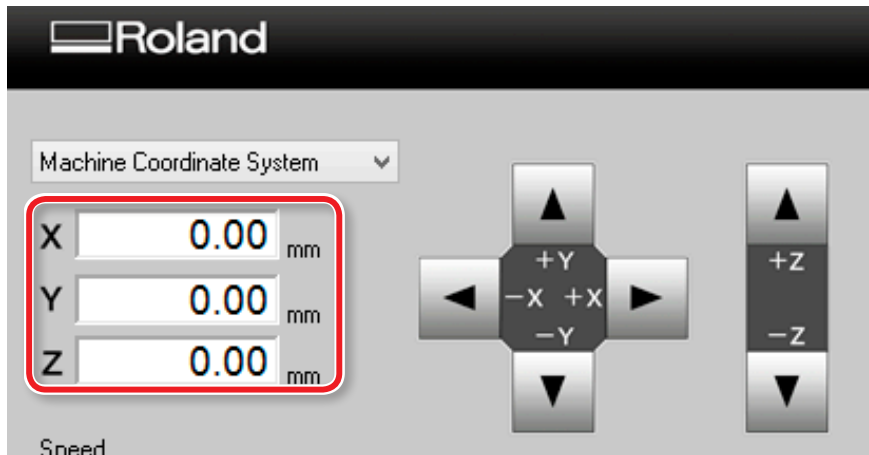

4. Select [User Coordinate System], check that XYZ is "0.00 mm."

If "0.00 mm" does not appear for X, Y and Z, click [X/Y], then [Z] under set origin point.



2. Set the origin point

1. Click [X][Y] feed button, move right above the origin point which put the mark by STEP1.

☞ User's Manual "Direction of Y axis using keypad"

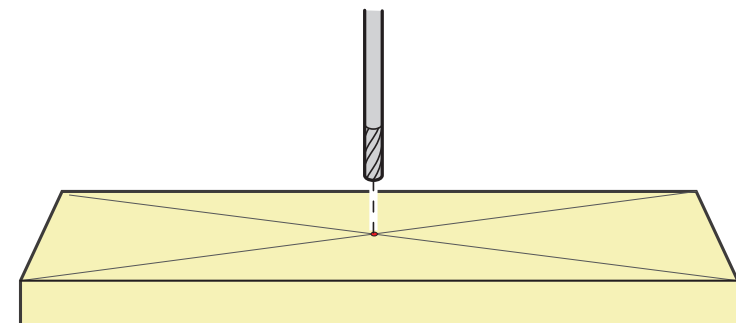
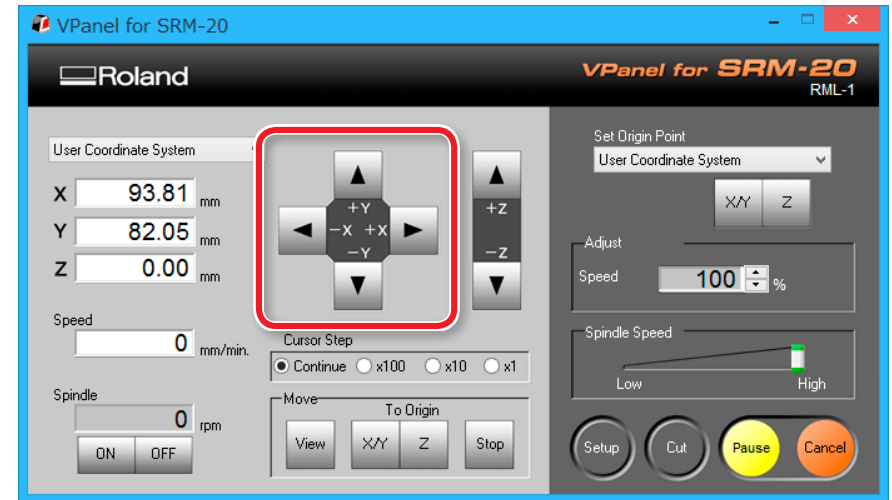



- 2.** Click the [- Z] feed button to approximate the tip of the cutting tool to the surface of the material as much as possible.

For loosening the set screw with the next procedure, move to the position that can see the hole of the set screw (to loosen the set screw with the hexagonal wrench).

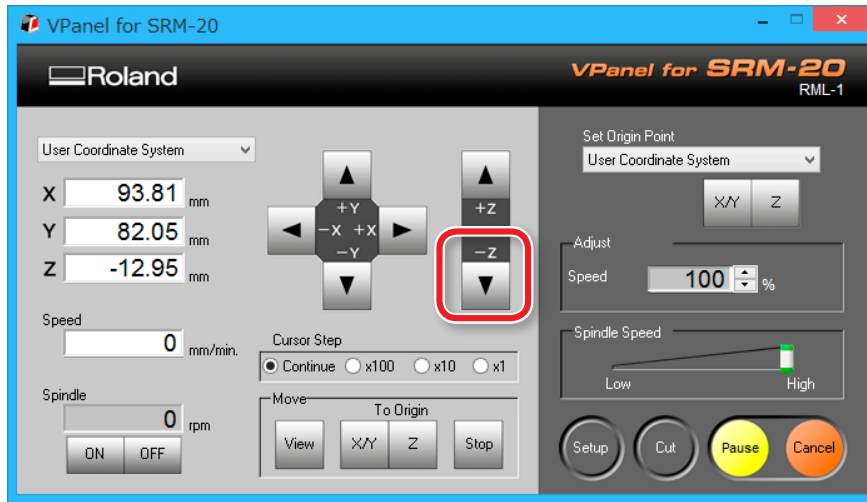

- 3.** Loosen the set screw, and then adjust the cutting tool so that its tip contacts the surface of the material.

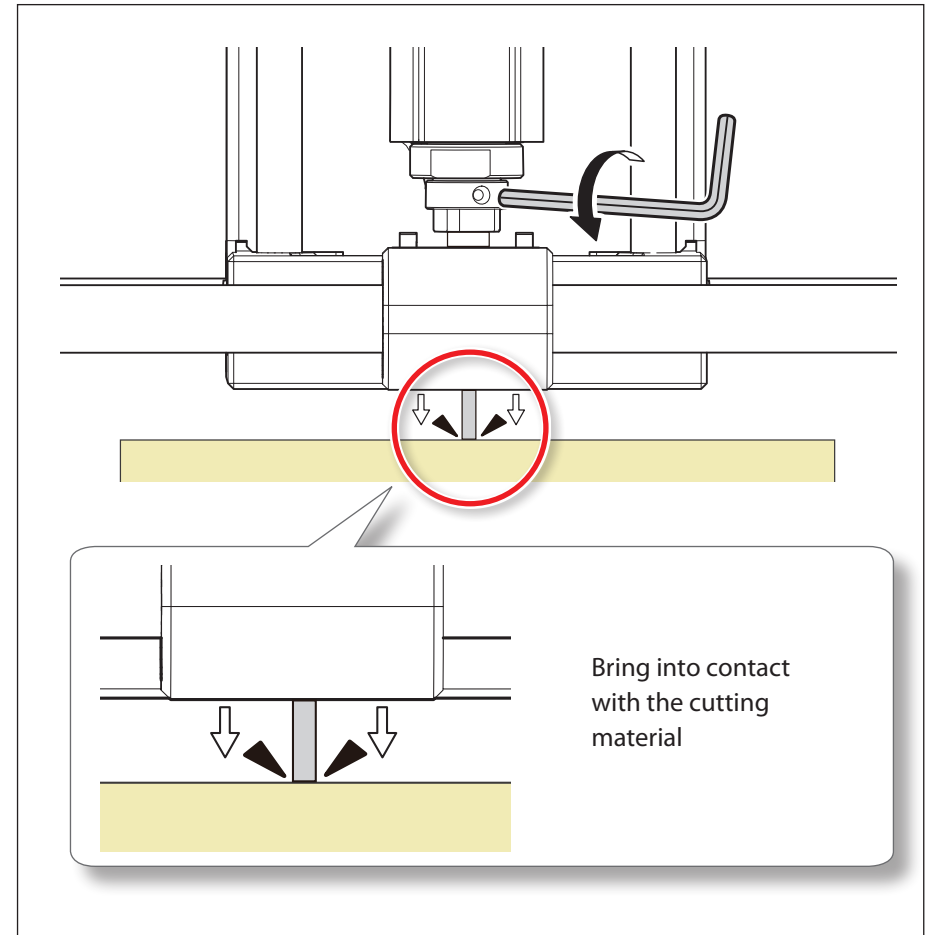



4. Tighten the cutting tool in place again with the set screw.

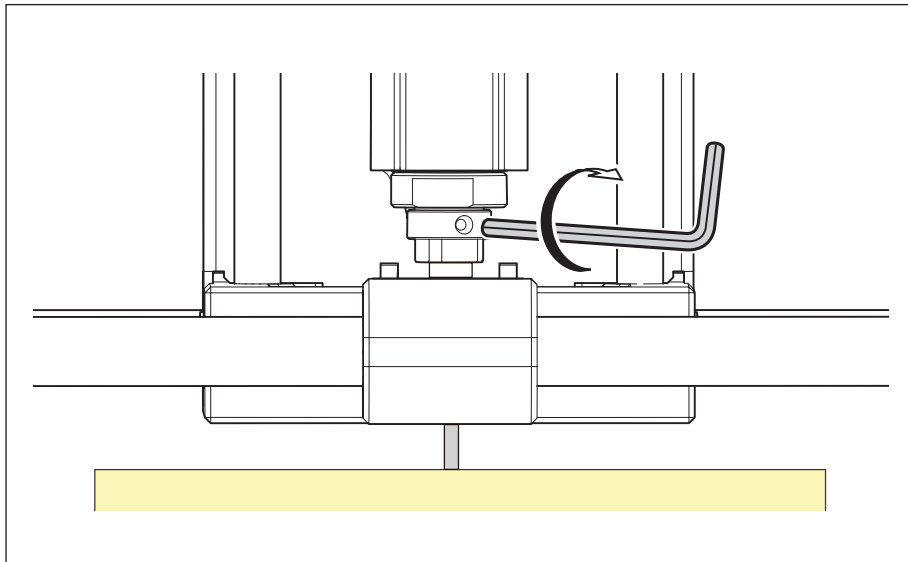

5. Click [X/Y][Z] of set origin point.



6. Click [YES].

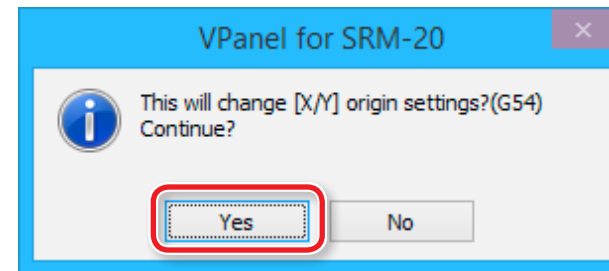

7. Confirm that the coordinates have all become "0."

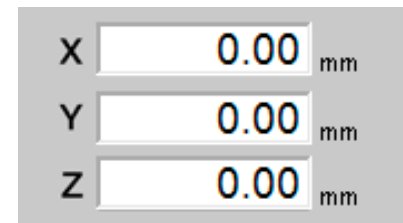

STEP 3 : Perform the Surface Leveling of the Scrap Board

The points to be checked before cutting

Check the following things before starting cutting. If there are problems with any of these, the cutting material may be wasted or the machine may be damaged.

- Is an output file right?
- Have you made a mistake with the origin point position?
- Do the cutting conditions match the type of cutting material?

Procedure

- 1.** Only enable the **“Scrap board Surfacing”** process on the MODEL A Player 4. (Figure at right)
 - 1-1. Click the unnecessary process of the cutting process list.
 - 1-2. Click  [Enable/Disable Cutting].
 - 1-3. Repeat procedures 1-1 and 1-2, and disable the processes that are not required.

 Only the orange processes  will be output.

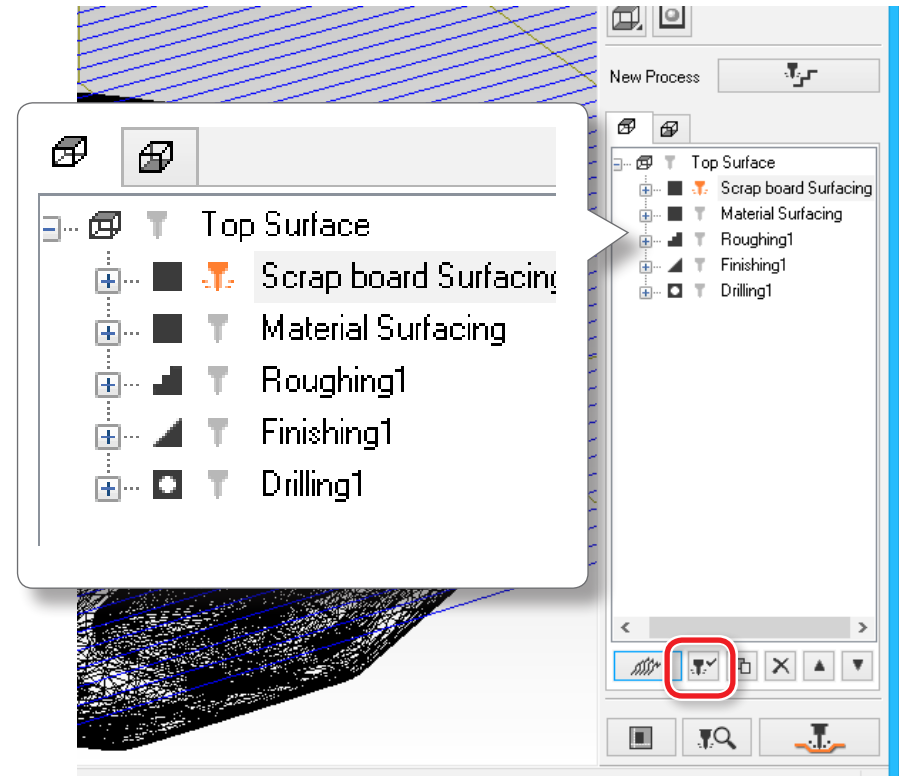



2. Click  [Cut].

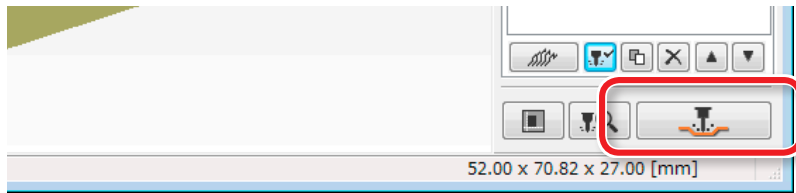

“When “Cutting Position Setup” is displayed” (p. 117)

3. Click [OK].

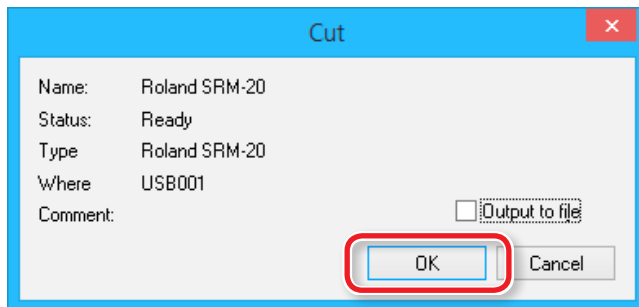

4. Click [Continue].

In the “Processed items,” outputting contents is displayed.

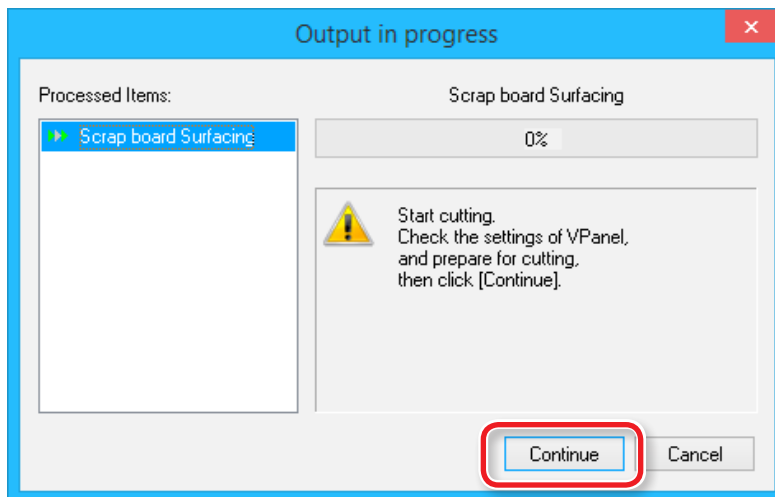

Pausing / Resuming

Click [Pause] of VPanel. The display of a button changes to [RESUME]. Click [RESUME] to resume.

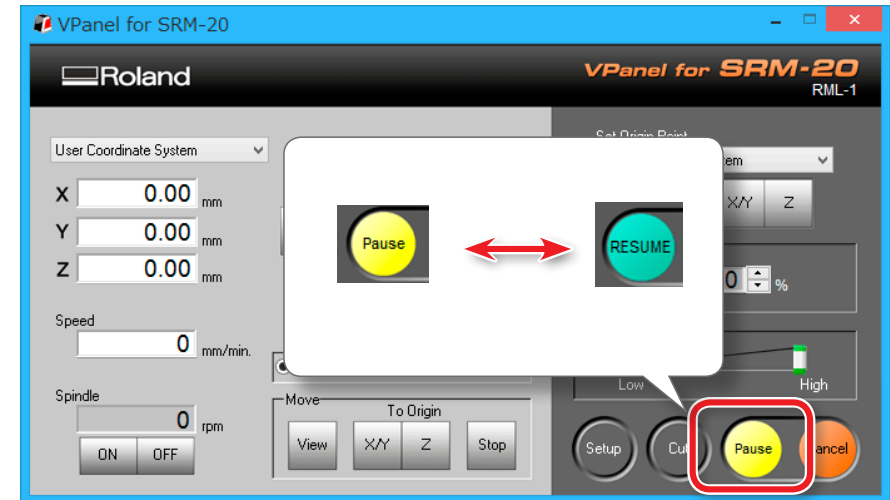

Cleaning during an extensive cutting operation (X,Z-axis)

If cutting waste accumulates during an extensive cutting operation, the machine's operation may be hindered, resulting in a product that does not meet expectations. Keep an eye on how much cutting waste builds up and pause the machine to remove the cutting waste that has built up around the X- and Z-axes before the movement worsens. Also remove the cutting waste in a dust tray.



If you [Pause] when the cutting tool is not touching the material, traces of cutting will be less likely to remain on the material.



Cancel the Cutting

When you want to cancel the cutting, click the **[Cancel]** of VPanel.
Outputting data is deleted .

☞ User's Manual **"It Takes Time to Delete Data After Quitting Cutting"**



Caution of Cutting After an Emergency Stop and a Shutdown

If an emergency stop or an emergency shutdown occurs during cutting, remove the cutting tool and the material from the machine. When the operation resumes, initialization is performed on the machine. At this time, the cutting tool and the material may collide depending on the position in which the tool and workpiece stopped, which can cause damage to the machine while restarting.

☞ User's Manual **"Responding to Error Messages"**

STEP 4 : Perform the Surface Leveling of the Material

Attach the material using the same procedure as the scrap board, and perform surface leveling.

Procedure

1. Attach the material to the scrap board.

* **Mark the location that will be the origin point of the material.**

MEMO

If you mount it in a position in the front, the work will be easier.

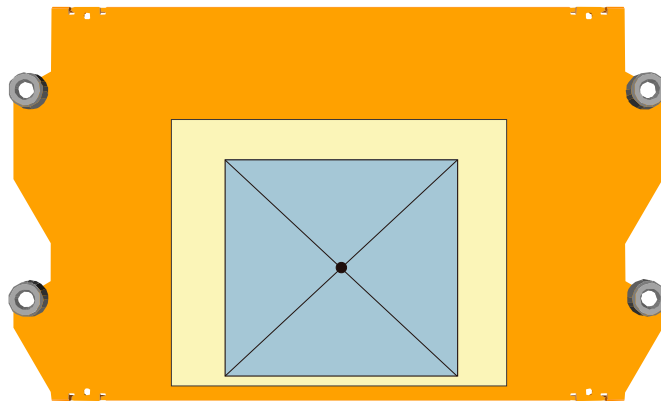

Front

2. Set the origin point to suit the material.

☞ **“STEP 2 : Set the Origin Point”** (p. 108)

3. Level the material surface.

Level the material surface using the same procedure as when leveling the scrap board surface. Output the data for the **“Level the material surface”** process.

☞ **“STEP 3 : Perform the Surface Leveling of the Scrap Board”** (p. 112)

Precautions to Take When Leveling the Material Surface

* **Make sure to reset the Z origin point to suit the material.**

Failure to perform this operation may result in the cutting tool hitting the material, which may cause the material to come loose and damage the cutting tool.

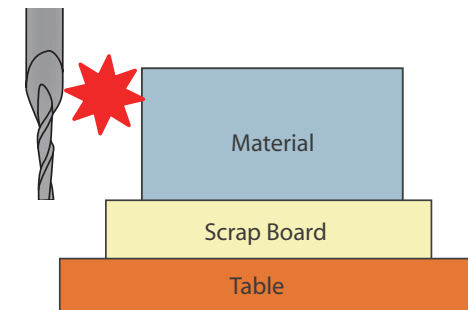
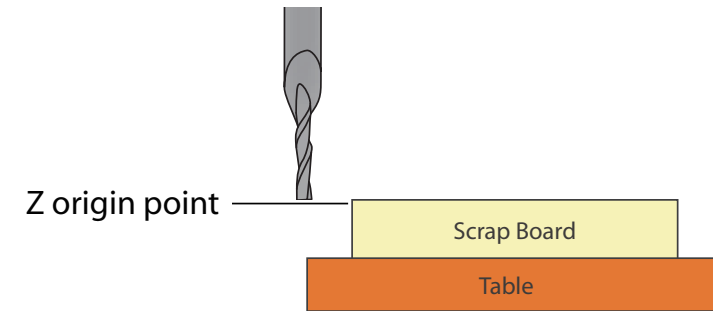

STEP 5 : Perform the Roughing

The points to be checked before cutting

Check the following things before starting cutting. If there are problems with any of these, the cutting material may be wasted or the machine may be damaged.



- Is an output file right?
- Have you made a mistake with the origin point position?
- Do the cutting conditions match the type of cutting material?

To change the cutting tool for each process, replace the cutting tool before outputting data.
 ➔ **"STEP 5 : Attach the Cutting Tool"** (p. 11)

Procedure

1. Enable the [Rounding 1] process only on the MODELA Player 4. (Figure at right)

- 1-1. Click the unnecessary process of the cutting process list.
- 1-2. Click  [Enable/Disable Cutting].
- 1-3. Repeat procedures 1-1 and 1-2, and disable the processes that are not required.

 Only the orange processes  will be output.

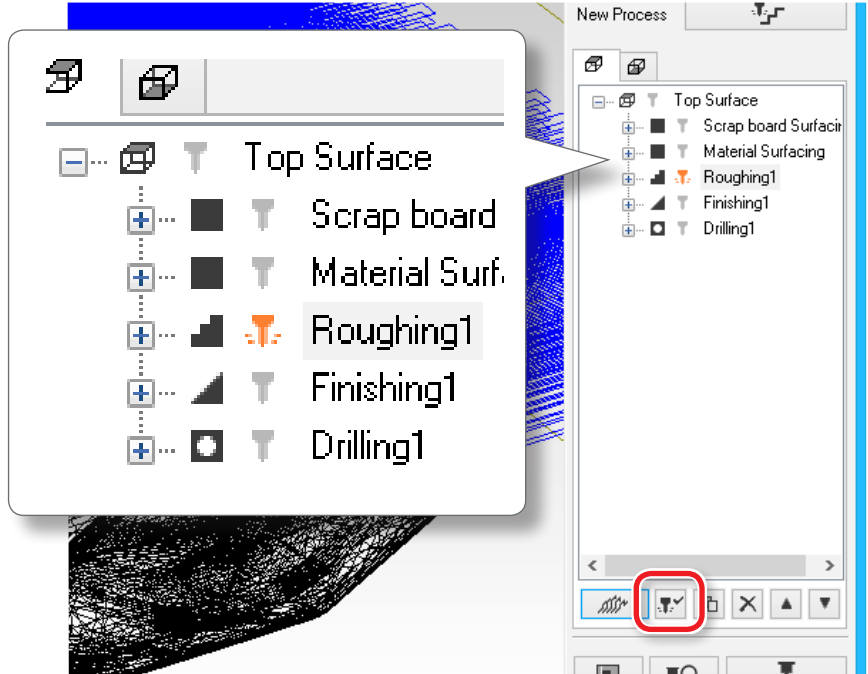

 If there is no need to switch the cutting tool, it is possible to select processes **"Material surfacing"** to **"Drilling"** and perform them all in a single operation.



2. Click  [Cut].

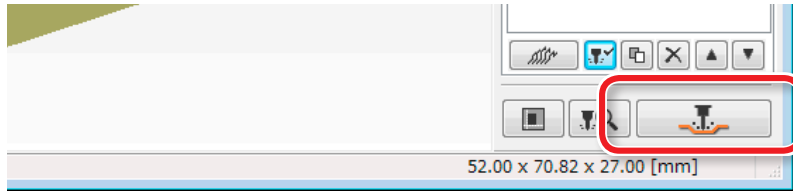

3. Click [OK].

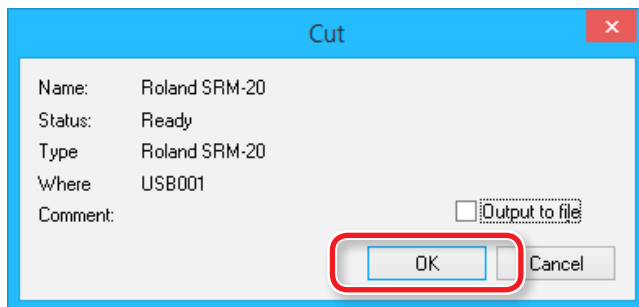

4. Click [Continue].

In the **“Processed items,”** outputting contents is displayed.

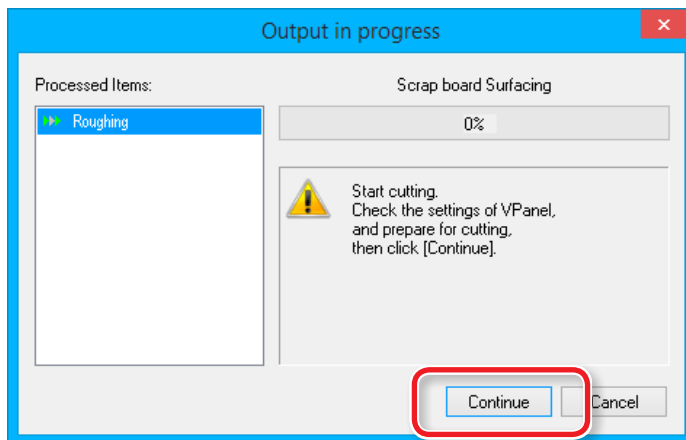

When “Cutting Position Setup” is displayed

If you have not performed a cutting preview in Virtual MODELA, **“Cutting-position Setup”** is displayed. Then Click **“OK.”**

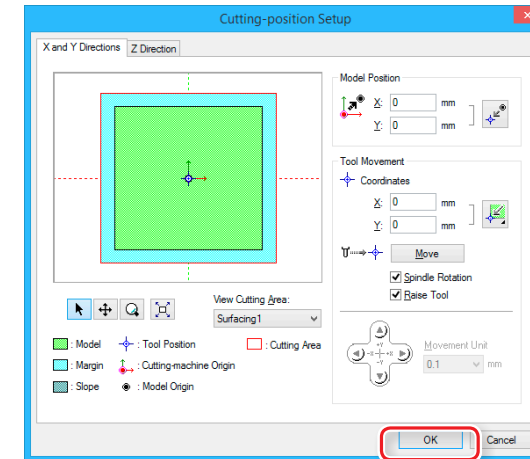

The feeding speed and number of rotations of a spindle can be adjusted during cutting by VPanel.

☞ User’s Manual **“Adjusting the feed rate and spindle speed during cutting”**

Clean the cutting waste constantly.

☞ **“Pausing / Resuming”** (p. 113)

STEP 6 : Perform the Finishing

The points to be checked before cutting

Check the following things before starting cutting. If there are problems with any of these, the cutting material may be wasted or the machine may be damaged.

- Is an output file right?
- Have you made a mistake with the origin point position?
- Do the cutting conditions match the type of cutting material?

To change the cutting tool for each process, replace the cutting tool before outputting data.
 ↩ "STEP 5 : Attach the Cutting Tool" (p. 11)

Procedure

1. Enable the [Finishing 1] process only on the MODELA Player 4. (Figure at right)

- 1-1. Click the unnecessary process of the cutting process list.
- 1-2. Click  [Enable/Disable Cutting].
- 1-3. Repeat procedures 1-1 and 1-2, and disable the processes that are not required.

 Only the orange processes  will be output.

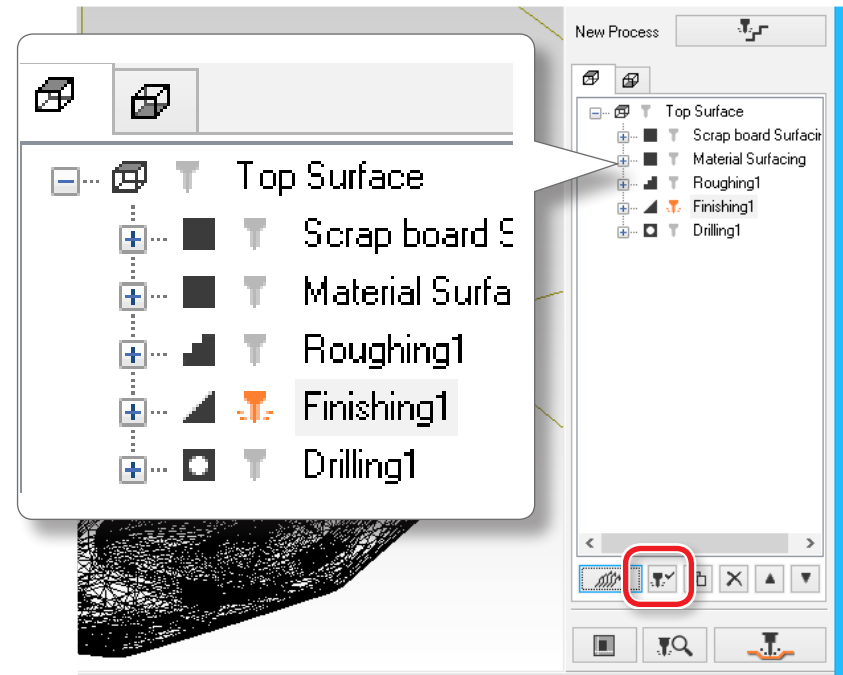

 If there is no need to switch the cutting tool, it is possible to select processes "Material surfacing" to "Drilling" and perform them all in a single operation.



2. Click  [Cut].

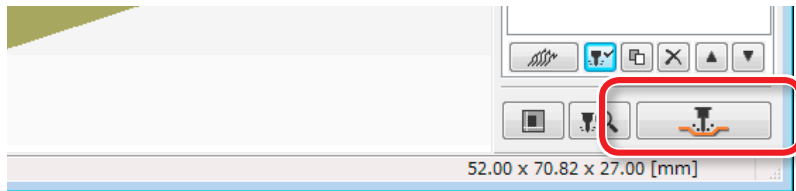

☞ "When "Cutting Position Setup" is displayed" (p. 117)

3. Click [OK].

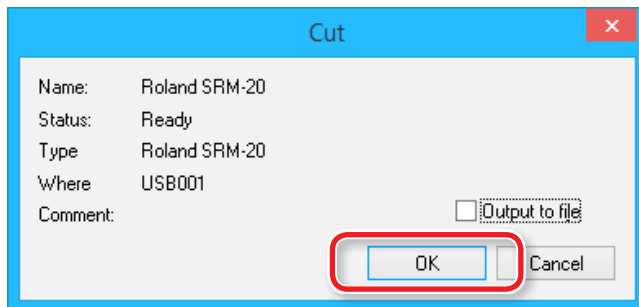

4. Click [Continue].

In the "Processed items," outputting contents is displayed.

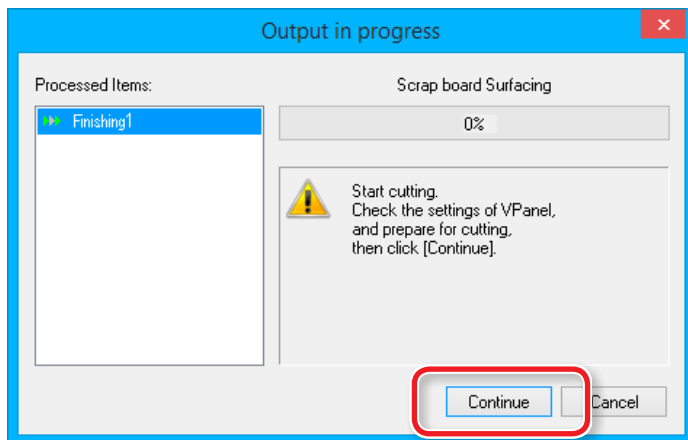

The feeding speed and number of rotations of a spindle can be adjusted during cutting by VPanel.

☞ User's Manual "Adjusting the feed rate and spindle speed during cutting"

Clean the cutting waste constantly.

☞ "Pausing / Resuming" (p. 113)



STEP 7 : Perform the Drilling in the Material

☞ “Reversal process using positioning pins” (p. 97)

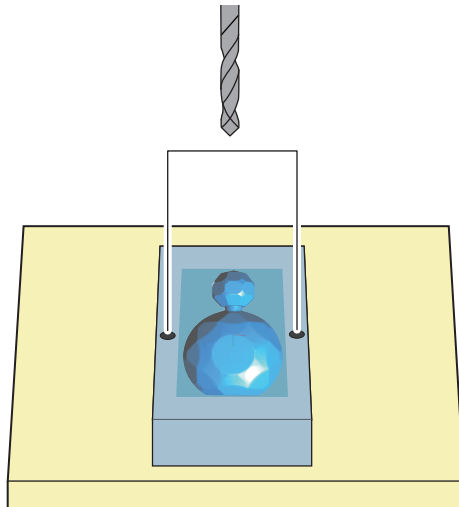
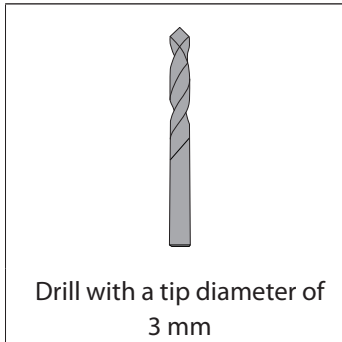

Procedure

1. Change the cutting tool to [3 mm Drill].

☞ “When changing to a cutting tool with the same shank diameter” (p. 13)

With MODELA Player 4, [Drill] is the only cutting tool that can be selected for a drilling process. However, you can perform a drilling process with [3 mm Drill] selected if you use the standard cutting tool that comes with the machine.

2. Only enable the “Drilling1” process only on the MODELA Player 4.

2-1. Click the unnecessary process of the cutting process list.

2-2. Click  [Enable/Disable Cutting].

2-3. Repeat procedures 1-1 and 1-2, and disable the processes that are not required.



If there is no need to switch the cutting tool, it is possible to select processes “Material surfacing” to “Drilling” and perform them all in a single operation.

3. Click [Cut].

☞ “When “Cutting Position Setup” is displayed” (p. 117)

4. Click [OK].

5. Click [Continue].



6. When drilling is completed, click [view] of VPanel, and remove the material.

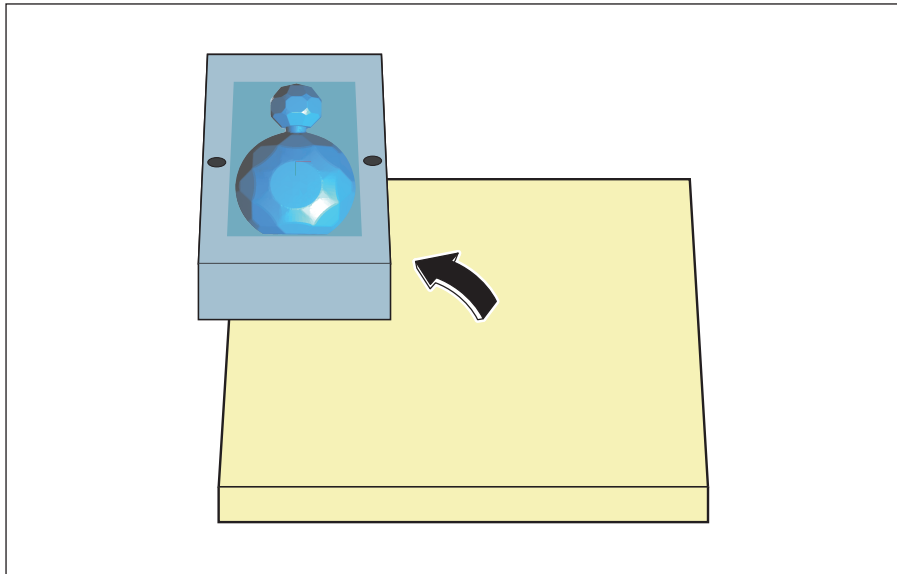

7. Make a mark on the material to ensure that you do not confuse the side to be reversed.

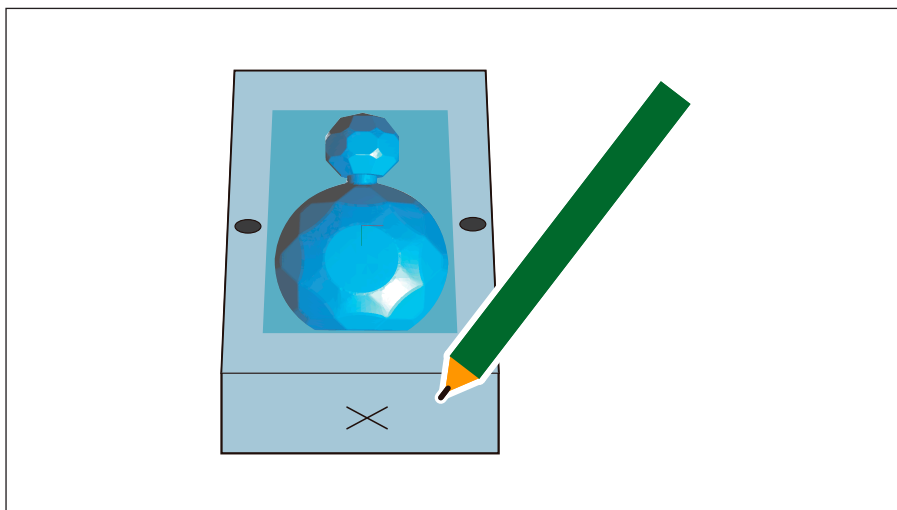

8. Measure the height of the material.

Confirm the height of the material after cutting. Measure correctly using slide calipers etc. If necessary, adjust the depth of the surface leveling of the bottom surface.

☞ **“STEP 9 : Set the Surface leveling Process of the Material”** (p. 83)

“Height of cutting data” - “Height of the material after cutting of top surface” = “Depth of surface leveling of bottom surface”

“Perfume.stl”

If the thickness of the material is **“28.5 mm,”** you don't need to adjust the depth of bottom surface leveling.

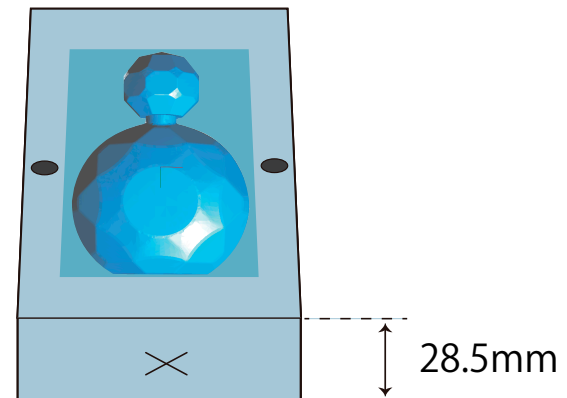

STEP 8 : Perform the Drilling in the Scrap Board

Drill holes in the same position as the hole positions of the material.



"If the scrap board is made from something harder than the material" (p. 79)

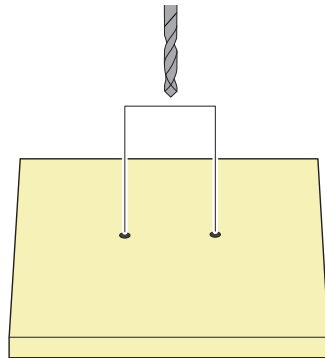

Procedure

1. Adjust the Z origin so that it fits the scrap board while leaving the other origins intact.

- 1-1. Click the [-Z] feed button on VPanel to bring the tip of the cutting tool as close to the top surface of the scrap board as possible.
- 1-2. Loosen the set screw of the machine and bring the tip of the cutting tool into contact with the top surface of the scrap board.
- 1-3. Using the set screw, fasten the cutting tool again.
- 1-4. Click [Z] of set origin point on the VPanel.

Set the Z origin alone, referring to steps 2 to 5 in **"STEP 3 : Set the Origin Point"** (p. 22).

* Failure to perform this operation, the cutting tool cannot reach and cut the scrap board.

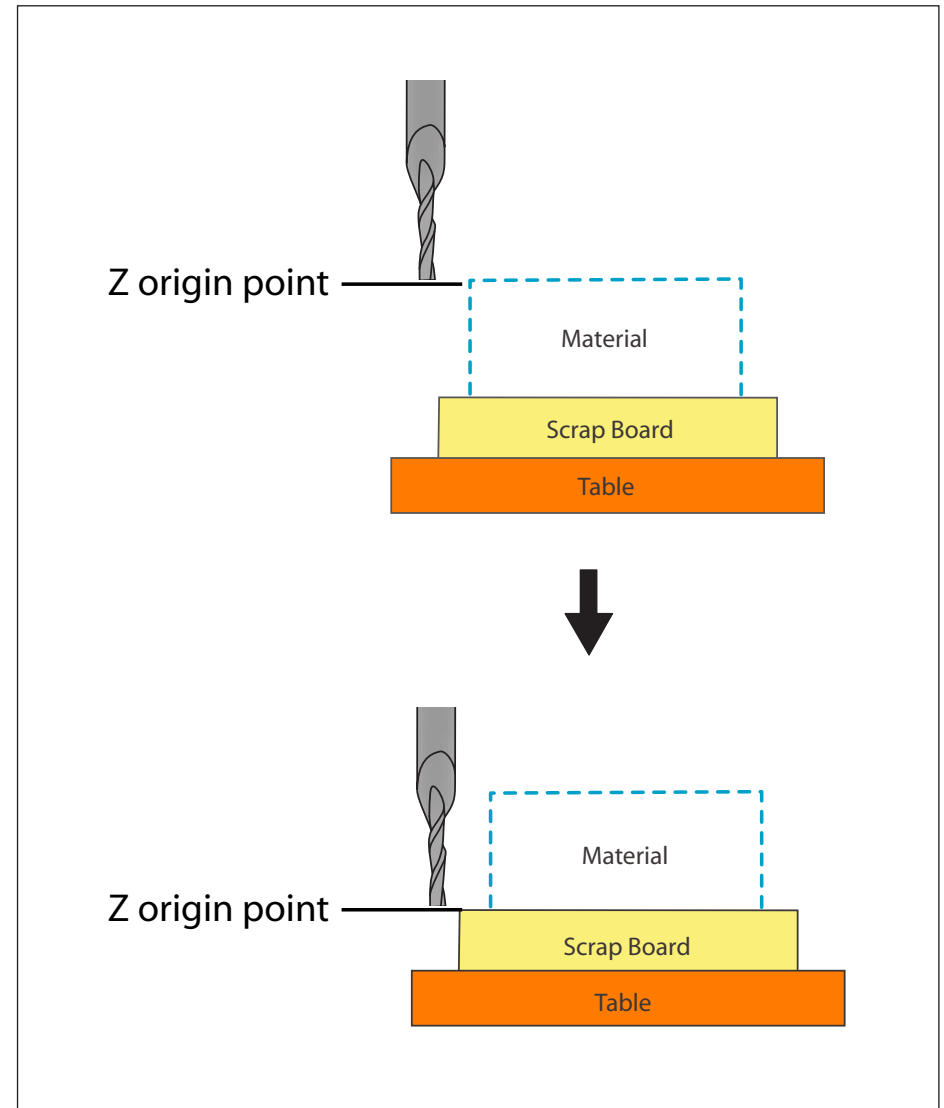



2. Only enable the "Drilling1" process only on the MODELA Player 4.

☞ "2. Only enable the "Drilling1" process only on the MODELA Player 4." (p. 120)

3. Click  [Cut].

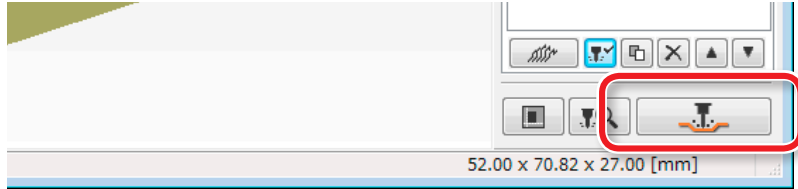

☞ "When "Cutting Position Setup" is displayed" (p. 117)

4. Click [OK].

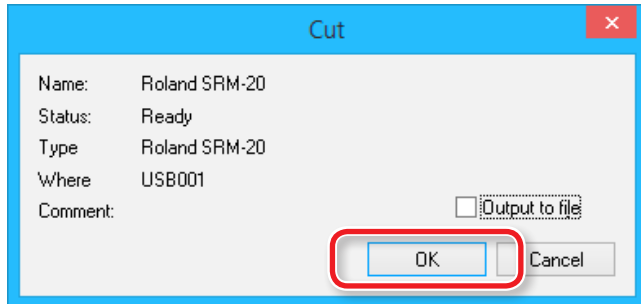

5. Click [Continue].

Cutting starts.

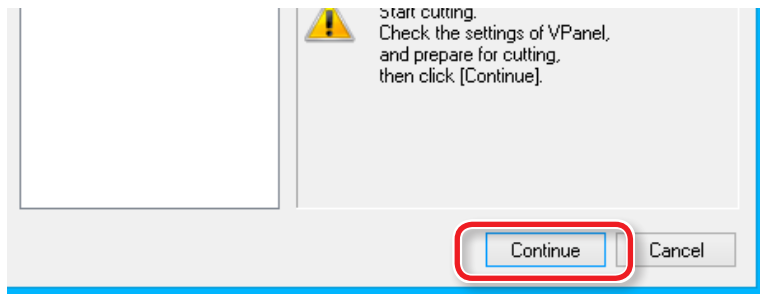

STEP 9 : Reverse the Material

Fix the material reversed using the positioning pin.

☞ "Reversal process using positioning pins" (p. 97)

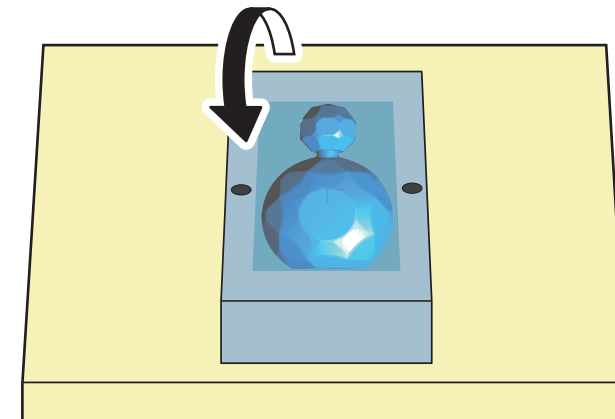
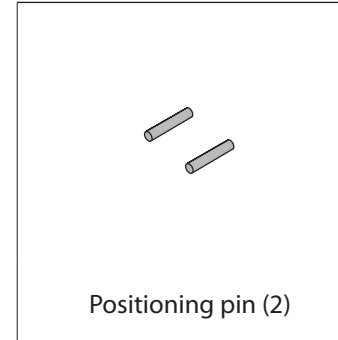



Procedure

1. Click [View] of VPanel.



2. Remove the cutting tool [3 mm Drill].

☞ **“When changing to a cutting tool with the same shank diameter”**
(p. 13)



You may not be able to produce the desired product if the movement worsens during the process because of built up cutting waste. Keep an eye on how much cutting waste builds up and, if deemed necessary, remove the cutting waste that has built up around the X- and Z-axes. Also remove the cutting waste that has collected in the dust tray.

3. Insert the positioning pins to the scrap board.

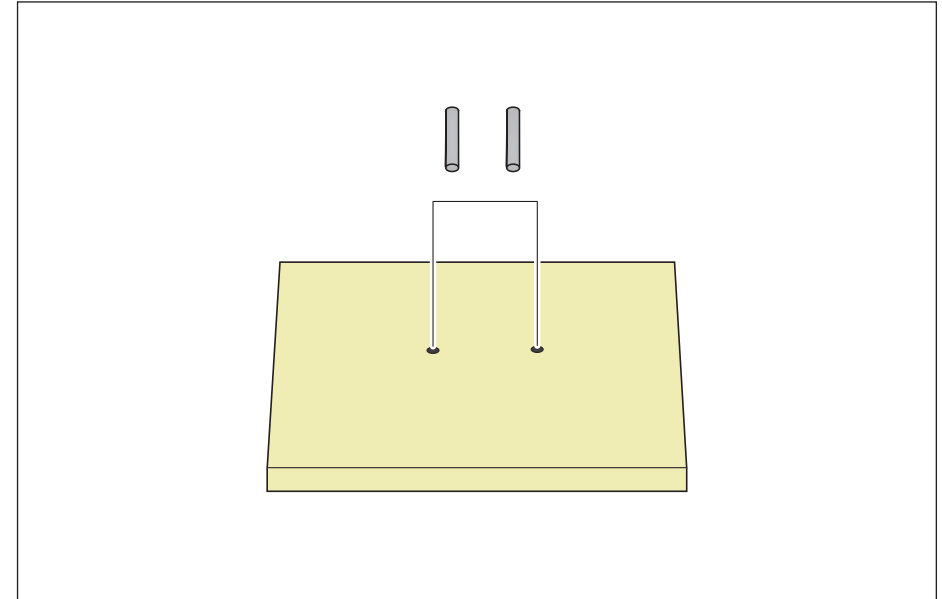

4. Affix double-sided tape to open areas of the top surface of the material.

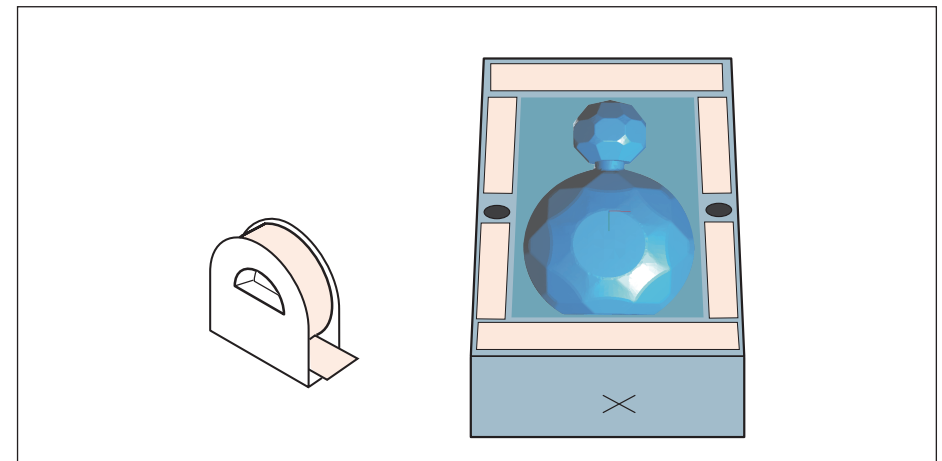



- 5.** Rotate the material 180° toward you around the X axis and align the pins with the holes in the material.

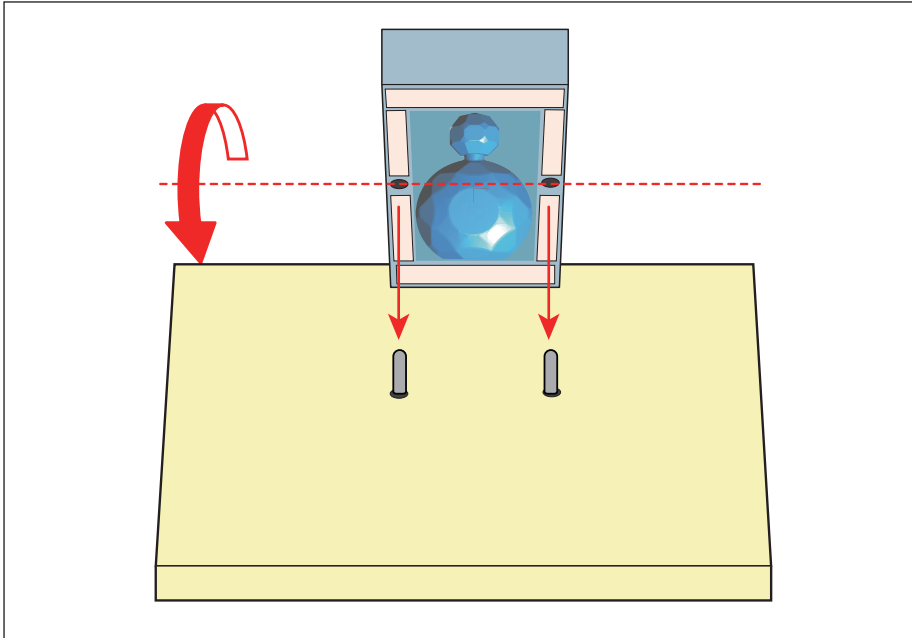

- 6.** Presses down from top and fixes firmly.
The side with the mark is the back.

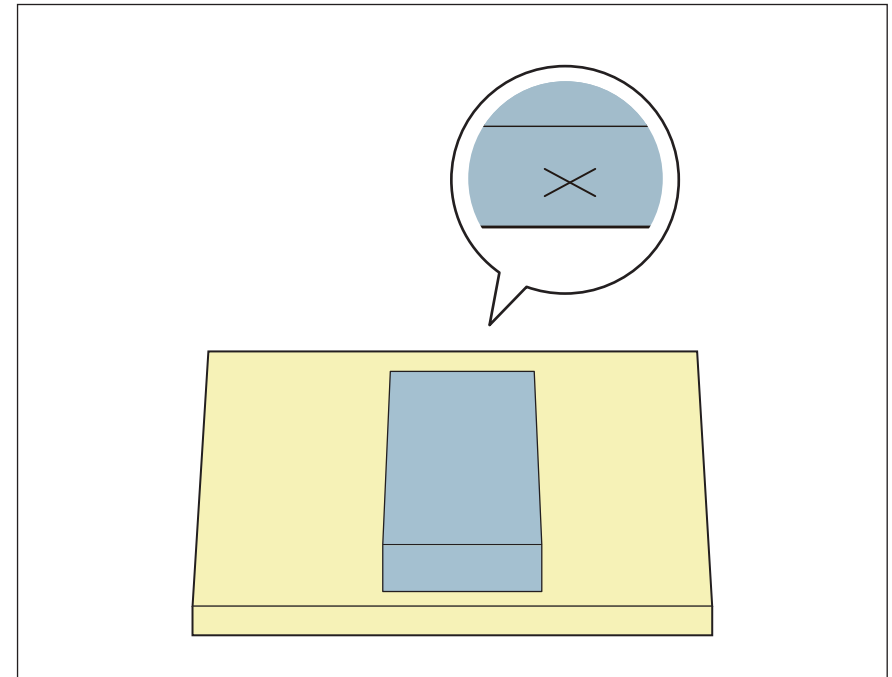

- 7.** Replace a cutting tool to [3 mm Square].
☞ “When changing to a cutting tool with the same shank diameter”
(p. 13)

STEP 10 : Cut the Bottom Surface

Select **[Bottom Surface]**.

Cut the bottom surface refer to the procedure of top surface cutting.

“STEP 4 : Perform the Surface Leveling of the Material” (p. 115)

“STEP 5 : Perform the Roughing” (p. 116)

“STEP 6 : Perform the Finishing” (p. 118)

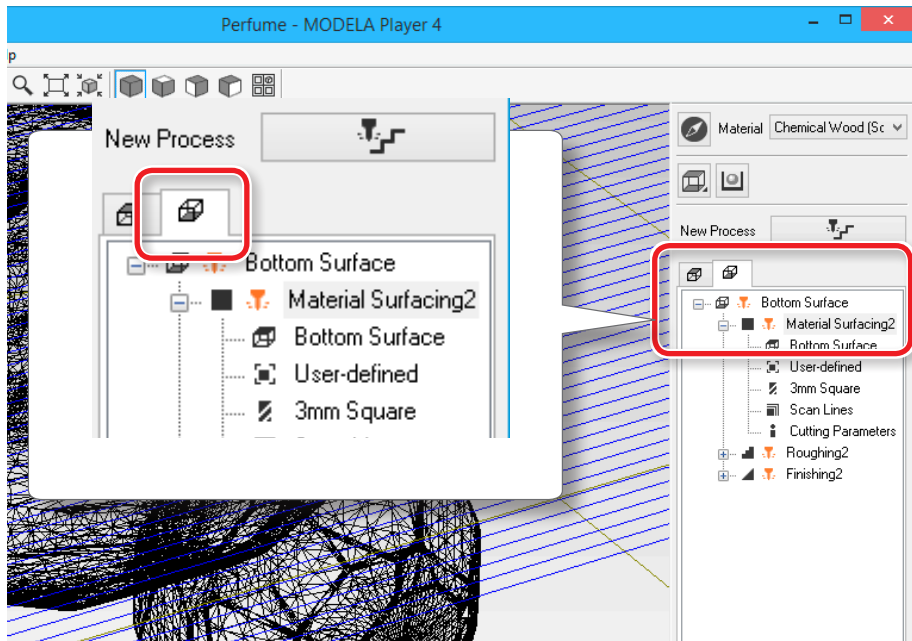

STEP 11 : Remove the Cut Material

MEMO

Depending on the settings configured on VPanel, the power may automatically turn off when a certain period of time elapses with the machine idle*.

* “Idle” means the state in which the movement of the table and spindle head is stopped (except when a cutting process is paused).

☞ User’s Manual “Power Option”

Procedure

1. Click **[View]** of VPanel.





2. Remove the cutting waste and remove the material.

Remove the double-stick tape on the back of the material.



When material cannot remove finely, it removes using wooden spatulas etc.

3. Remove the support parts.



STEP 12 : Turning the Power Off

Push **[⏻]** (Power) button.

A LED lamp lights off. After cutting, clean the cutting waste certainly.

☞ User's Manual **"Cleaning after Cutting Operation Ends"**

